

DEMO LEGEND

X TREE TO BE REMOVED

- - - EXISTING FEATURE TO BE REMOVED

DEEP TEST HOLE DESCRIPTIONS

DT-1	0"-6" TOP SOIL 6"-84" SAND WITH COBBLES NO WATER NO LEDGE
DT-2	0"-6" TOP SOIL 6"-97" LIGHT BROWN SANDY LOAM WITH BROKEN ROCK NO WATER NO LEDGE
DT-3	0"-6" TOP SOIL 6"-99" SAND WITH COBBLES NO WATER NO LEDGE
DT-4	0"-6" GRAVEL 6"-12" TOP SOIL 12"-84" BROWN SANDS WITH COBBLES NO WATER NO LEDGE

PERCOLATION TEST

PT1	6 MIN/INCH
PT2	NO PERC
PT3	5 MIN/INCH
PT4	3.3 MIN/INCH

*10 MIN/INCH WAS UTILIZED FOR THE SIZING CALCULATIONS OF THE STORMWATER DETENTION SYSTEM.

TREE DEMO LIST

SIZE	NAME/TYPE	QTY
16"	TREE	1
18"	TREE	1
20"	TREE	1
		TREE 3

TREE NOTE:

1. A TOTAL OF THREE (3) TREES SHALL BE REMOVED ON THIS APPLICATION.

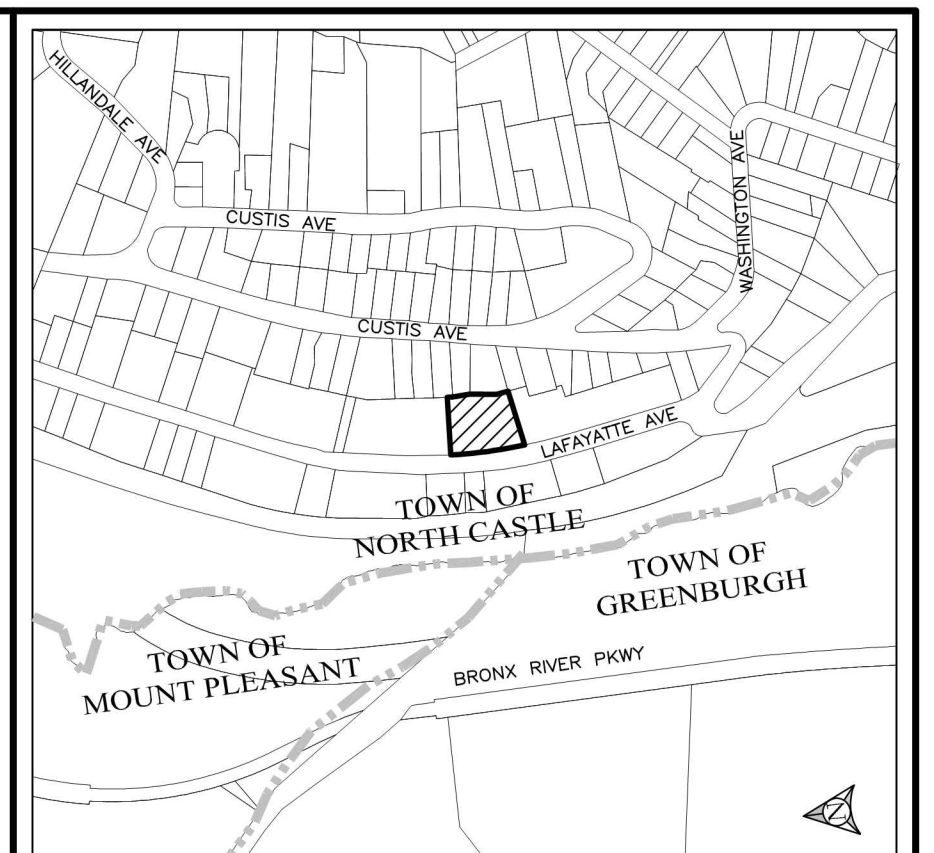

LOCATION MAP N.T.S.

- CONSTRUCTION NOTES:**
- THE CONTRACTOR SHALL LOCATE AND VERIFY IN THE FIELD ALL UTILITIES: SEWER, WATER, GAS, ELECTRICAL, ETC. PRIOR TO THE START OF CONSTRUCTION. CONTRACTOR SHALL CALL CODE 753 (FORMERLY CODE 53) PRIOR TO THE START OF CONSTRUCTION.
 - THE INSTALLATION OF WATER AND SEWER SHALL BE INSPECTED UNDER THE DIRECTION OF A N.Y. STATE LICENSED PROFESSIONAL ENGINEER.
 - EROSION AND SEDIMENT CONTROL MEASURES SHALL BE REQUIRED AS INDICATED ON THIS PLAN OR THE EROSION CONTROL PLAN OR AS DIRECTED BY THE GOVERNING AGENCY, IN ACCORDANCE WITH THE CURRENT EDITION OF "NEW YORK STATE STANDARDS AND SPECIFICATIONS FOR EROSION AND SEDIMENT CONTROLS" (BLUE BOOK).
 - AS BUILT PLANS IF REQUIRED, SHALL BE CERTIFIED BY A N.Y. STATE LICENSED SURVEYOR OR PROFESSIONAL ENGINEER.
 - ALL PROPERTY DISTURBED IN THE RIGHT-OF-WAY OR ON PRIVATE LANDS, SHALL BE RESTORED TO ACCEPTABLE CONDITIONS, AS REQUIRED BY THE GOVERNING AGENCY.
 - THE CONTRACTOR SHALL BE RESPONSIBLE FOR ALL APPLICATIONS AND PERMITS REQUIRED FOR CONSTRUCTION.
 - THE ROAD AND UTILITIES SHALL BE STAKED IN THE FIELD BY A NEW YORK STATE LICENSED SURVEYOR OR ENGINEER.
 - UNDERGROUND UTILITIES: GAS, ELECTRIC, CABLE, TELEPHONE, ETC. SHALL BE AS REQUIRED BY THE GOVERNING AGENCY AND THE APPROPRIATE UTILITY COMPANY.
 - ALL PROPOSED OR DISTURBED SLOPES, 1H:3V OR GREATER SHALL BE STABILIZED WITH AN EROSION CONTROL BLANKET.
 - IN LIEU OF BLASTING, ROCK RIPPING WILL BE USED WHEREVER POSSIBLE. IF BLASTING IS REQUIRED, BLASTING WILL OCCUR IN ACCORDANCE WITH REGULATIONS AND STANDARDS PRESCRIBED BY THE GOVERNING AGENCY. CONTRACTOR IS RESPONSIBLE FOR ALL NECESSARY PERMITS IF BLASTING IS REQUIRED.
 - NO REPRESENTATION OF THE SUB-SURFACE SOIL CONDITIONS ON THIS SITE ARE MADE OR IMPLIED. IT IS THE DEVELOPER/CONTRACTOR'S RESPONSIBILITY TO ENSURE ALL IMPROVEMENTS ARE PLACED ON SOIL WITH A SUITABLE BEARING CAPACITY.

GENERAL NOTES:

1. EXISTING FEATURES SHOWN HEREON WERE TAKING FROM SURVEY MAP ENTITLED "TOPOGRAPHIC SURVEY OF PROPERTY SITUATE IN THE TOWN OF NORTH CASTLE, WESTCHESTER COUNTY, NEW YORK, PREPARED BY LINK LAND SURVEYORS P.C. DATED MAY 9, 2022".



IT IS A VIOLATION OF THE NEW YORK STATE EDUCATION LAW, ARTICLE 145, SECTION 7209(2), FOR ANY PERSON, UNLESS HE IS ACTING UNDER THE DIRECTION OF A LICENSED PROFESSIONAL ENGINEER OR LAND SURVEYOR, TO ALTER ANY ITEM ON THIS PLAN IN ANY WAY. IF ANY ITEM BEARING THE SEAL OF AN ENGINEER OR LAND SURVEYOR IS ALTERED, THE ALTERING ENGINEER OR LAND SURVEYOR SHALL AFFIX TO THE ITEM HIS SEAL AND THE NOTATION "ALTERED BY" FOLLOWED BY HIS SIGNATURE AND THE DATE OF SUCH ALTERATION, AND A SPECIFIC DESCRIPTION OF THE ALTERATION.

North arrow and scale: 1" = 10'

ALFONZETTI ENGINEERING, P.C.
 14 SMITH AVE, MT. KISCO, N.Y. 10549
 914-666-9800 INFO@ALFONZETTIENG.COM

SITE DATA		REVISED: JUNE 8, 2023 REVISED: DECEMBER 12, 2022
OWNER/APPLICANT: 2012 MARIA MARTINS IRREVOCABLE TRUST	REVISIONS:	
SITE ADDRESS: 78 LAFAYETTE AVE. NORTH WHITE PLAINS, NY 10603	DATE:	
TAX MAP #: 122.12-1-29	DATE:	
LOT AREA: 0.6115 AC	DATE:	
ZONING: IND-A	DATE:	
EXISTING CONDITIONS & DEMOLITION PLAN		SHEET 01 OF 05
JUNE 13, 2022		
PROJECT: 78 LAFAYETTE AVENUE TOWN OF NORTH CASTLE, WESTCHESTER COUNTY, NEW YORK		

FIRE DISTRICT: NORTH WHITE PLAINS FD
 SCHOOL DISTRICT: VALHALLA
 WATER DISTRICT: NORTH CASTLE WD#1
 APPROVED BY TOWN OF NORTH CASTLE PLANNING BOARD RESOLUTION, DATE: _____

DATE: _____
 CHRISTOPHER CARTHY, CHAIRMAN
 TOWN OF NORTH CASTLE PLANNING BOARD

ENGINEERING PLANS REVIEWED FOR CONFORMANCE TO RESOLUTION: _____

DATE: _____
 JOSEPH M. CERMELE, P.E.
 KELLARD SESSIONS CONSULTING
 CONSULTING TOWN ENGINEERS

LAFAYETTE AVENUE

PLANT SCHEDULE

QUANTITY	BOTANICAL NAME	COMMON NAME	SIZE
8	RED MAPLE	ACER RUBRUM	2-3.5 CALIPER
6	ARONIA ARBUTIFOLIA	RED CHOKECHERRY	3 GAL.

PARKING REQUIREMENTS

	UNITS/AREA	REQUIRED	PROVIDED
WAREHOUSE SPACE (1 SPACE/1,200 SQ.FT.)	6,020 S.F.	5.02	
OFFICE (2 STORIES) (1 SPACE/250 SQ.FT.)	1,050 S.F. x 2 = 2,100 S.F.	8.4	
TOTAL		13.42	14

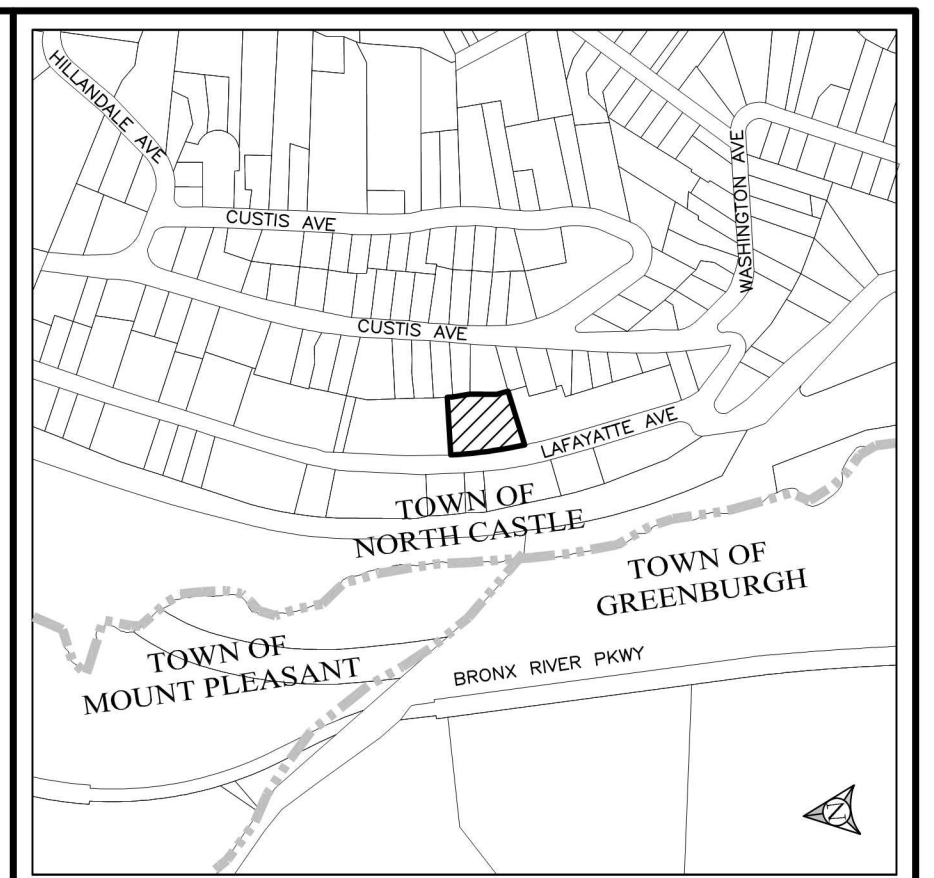
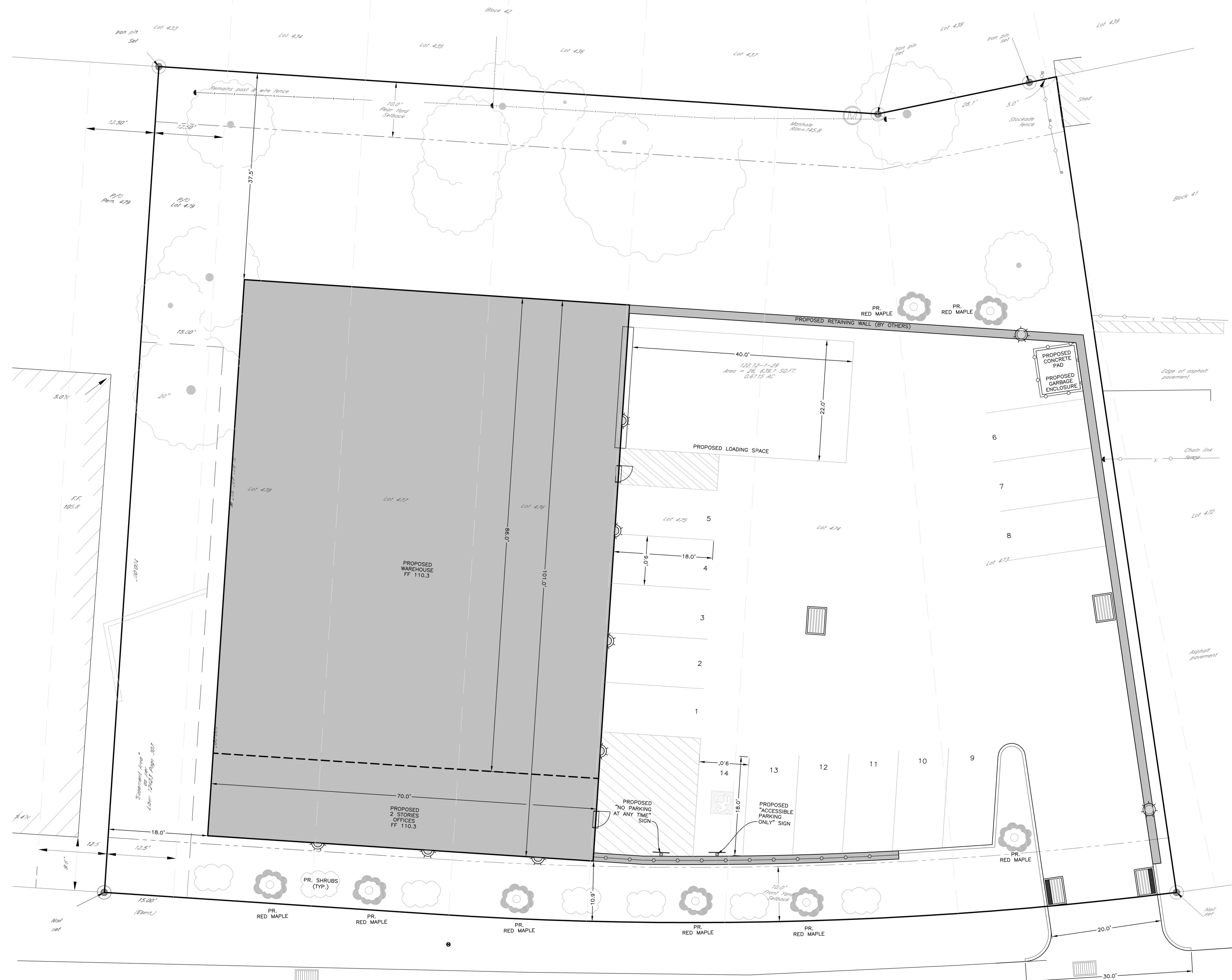

LOCATION MAP N.T.S.

ZONING CONFORMANCE TABLE

ZONING DISTRICT	IND-A (INDUSTRIAL A DISTRICT)	
	REQUIRED OR ALLOWED	PROPOSED
GROSS LOT AREA		26,639.1 S.F.
75% WETLAND AREA		0.0 S.F.
50% STEEP SLOPES 25%+		6,810.0 S.F.
MINIMUM NET LOT AREA	5,000 S.F.	19,829.1 S.F.
LOT FRONTAGE	50 FT.	194.69 FT
LOT DEPTH	100 FT.	132 FT.
FRONT YARD SETBACK	10 FT.	10.9 FT
SIDE YARD SETBACK	0 FT.	18 FT
REAR YARD SETBACK	10 FT.	37.5 FT.
MAXIMUM BUILDING COVERAGE	40%	28.53%
		(7,070 S.F.)
BUILDING HEIGHT	2 STORIES/ 35 FEET	2.0 STORIES/ 20 FEET
FLOOR AREA RATIO	0.6	0.46



IT IS A VIOLATION OF THE NEW YORK STATE EDUCATION LAW, ARTICLE 145, SECTION 7209(2), FOR ANY PERSON, UNLESS HE IS ACTING UNDER THE DIRECTION OF A LICENSED PROFESSIONAL ENGINEER OR LAND SURVEYOR, TO ALTER ANY ITEM ON THIS PLAN IN ANY WAY. IF ANY ITEM BEARING THE SEAL OF AN ENGINEER OR LAND SURVEYOR IS ALTERED, THE ALTERING ENGINEER OR LAND SURVEYOR SHALL AFFIX TO THE ITEM HIS SEAL AND THE NOTATION "ALTERED BY" FOLLOWED BY HIS SIGNATURE AND THE DATE OF SUCH ALTERATION, AND A SPECIFIC DESCRIPTION OF THE ALTERATION.

North arrow pointing up and slightly right. Scale bar showing 0, 5, 10, 20 feet. Scale: 1" = 10'. Professional Engineer seal for Ralph Alfonzetti, State of New York, License No. 17624.

ALFONZETTI ENGINEERING, P.C.
14 SMITH AVE, MT. KISCO, N.Y. 10549
914-666-9800 INFO@ALFONZETTIENG.COM

SITE DATA
OWNER/APPLICANT: 2012 MARIA MARTINS IRREVOCABLE TRUST
SITE ADDRESS: 78 LAFAYETTE AVE, NORTH WHITE PLAINS, NY 10603
TAX MAP #: 122.12-1-29
LOT AREA: 0.6115 AC
ZONING: IND-A
REVISIONS: REVISED: JUNE 8, 2023; REVISED: DECEMBER 12, 2022

LAYOUT/PLANTING PLAN
JUNE 13, 2022

PROJECT: 78 LAFAYETTE AVENUE
TOWN OF NORTH CASTLE,
WESTCHESTER COUNTY, NEW YORK

DATE: _____
CHRISTOPHER CARTHY, CHAIRMAN
TOWN OF NORTH CASTLE PLANNING BOARD

DATE: _____
JOSEPH M. CERMELE, P.E.
KELLARD SESSIONS CONSULTING
CONSULTING TOWN ENGINEERS

LAFAYETTE AVENUE

EROSION CONTROL NOTES:

- CONTRACTOR SHALL BE RESPONSIBLE FOR COMPLIANCE WITH ALL SEDIMENT AND EROSION CONTROL PRACTICES. THE SEDIMENT AND EROSION CONTROL PRACTICES ARE TO BE INSTALLED PRIOR TO ANY MAJOR SOIL DISTURBANCES, AND MAINTAINED IN EFFECTIVE CONDITION THROUGHOUT THE CONSTRUCTION PERIOD OR UNTIL PERMANENT PROTECTION IS ESTABLISHED.
- PRIOR TO ANY EXCAVATION, SILT FENCE SHALL BE INSTALLED AT THE LOCATIONS NOTED ON THE EROSION CONTROL PLAN. ADDITIONAL SILT FENCE MAY BE REQUIRED BY THE ENGINEER IN THE FIELD. SILT FENCING SHALL BE MAINTAINED IN EFFECTIVE CONDITION AND SHALL NOT BE REMOVED UNTIL DISTURBED AREAS ARE THOROUGHLY STABILIZED.
- INSTALL ANTI-TRACKING PAD AT ALL CONSTRUCTION ENTRANCES. ANTI-TRACKING PAD SHALL BE 2'-3" DIAMETER CRUSHED STONE 6" DEEP.
- TIMELY MAINTENANCE OF SEDIMENT CONTROL STRUCTURES IS THE RESPONSIBILITY OF THE CONTRACTOR. ALL STRUCTURES SHALL BE MAINTAINED IN GOOD WORKING ORDER AT ALL TIMES. THE SEDIMENT LEVEL IN ALL SEDIMENT REMOVING DEVICES SHALL BE CLOSELY MONITORED AND SEDIMENT REMOVED PROMPTLY WHEN MAXIMUM LEVELS ARE REACHED OR AS ORDERED BY THE ENGINEER. SEDIMENT SHALL BE DISPOSED OF IN A MANNER THAT DOES NOT RESULT IN ADDITIONAL EROSION OR POLLUTION. ALL SEDIMENT CONTROL STRUCTURES SHALL BE INSPECTED ON A REGULAR BASIS, AND IMMEDIATELY AFTER EACH RAINFALL TO INSURE PROPER OPERATION AS DESIGNED. ANY REQUIRED REPAIRS SHALL BE MADE IMMEDIATELY.
- ALL TOPSOIL NOT TO BE USED FOR FINAL GRADING SHALL BE REMOVED FROM THE SITE IMMEDIATELY AND PLACED IN A STABILIZED STOCKPILE OR FILL AREA. ALL TOPSOIL REQUIRED FOR FINAL GRADING AND STORED ON SITE SHALL BE LIMED, FERTILIZED, TEMPORARILY SEEDED AND MULCHED WITHIN 14 DAYS OR OTHERWISE STABILIZED. DO NOT STOCKPILE MATERIALS ON STEEP SLOPES, IN DRAINAGE SWALES OR IN WETLAND AREAS. SURROUND ALL STOCKPILE AREAS WITH STAKED HAYBALES OR SILT FENCE.
- ALL SLOPES CONSTRUCTED WITH FILL MATERIAL AND ALL SLOPES WITH GRADE 3:1 OR STeeper SHALL BE TOPSOILED, SEEDED, MULCHED AND STABILIZED WITH STAKED TOBACCO NETTING, OR EROSION BLANKET AS NOTED, UNLESS OTHERWISE DIRECTED.
- ANY DISTURBED AREAS THAT WILL BE LEFT EXPOSED MORE THAN 14 DAYS AND NOT SUBJECT TO CONSTRUCTION TRAFFIC, SHALL IMMEDIATELY RECEIVE TEMPORARY SEEDING. MULCH SHALL BE USED IF THE SEASON PREVENTS THE ESTABLISHMENT OF A TEMPORARY COVER. DISTURBED AREAS SHALL BE LIMED AND FERTILIZED PRIOR TO TEMPORARY SEEDING.
- ALL DISTURBED AREAS WITHIN 500 FEET OF A BUILDING SHALL BE WETTED AS NECESSARY TO PROVIDE DUST CONTROL. A WATERING TRUCK WILL BE USED IN DRY SEASON TO WET DOWN DUST AREAS.
- THE CONTRACTOR SHALL KEEP THE ROADWAYS WITHIN THE PROJECT CLEAR OF SOIL AND DEBRIS AND IS RESPONSIBLE FOR ANY STREET CLEANING NECESSARY DURING THE COURSE OF THE PROJECT.
- ALL CATCH BASINS AND DRAIN INLETS ARE TO BE PROTECTED WITH SEDIMENT FILTERS THROUGHOUT THE CONSTRUCTION PERIOD AND UNTIL ALL DISTURBED AREAS ARE STABILIZED.
- UTILITY LINE EXCAVATED MATERIAL SHALL BE TEMPORARILY STOCKPILED ON THE HIGH SIDE OF EXCAVATION SO RUNOFF IS DIRECTED AWAY FROM TRENCH. AFTER BACK-FILLING, AREA IS TO BE TOPSOILED, SEEDED AND MULCHED.
- SEDIMENT AND EROSION CONTROL STRUCTURES SHALL BE REMOVED AND THE AREA STABILIZED WHEN THE DRAINAGE AREA HAS BEEN PROPERLY STABILIZED BY PERMANENT MEASURES.
- ALL AREAS OF DISTURBED SOIL SHALL BE STABILIZED BY THE CONTRACTOR. IN ADDITION TO ALL SPECIFIED EROSION CONTROL DEVICES, THE CONTRACTOR SHALL TAKE ALL STEPS PRUDENT AND NECESSARY TO STABILIZE THE SITE AT ALL TIMES.
- ALL SEDIMENT AND EROSION CONTROL MEASURES SHALL BE INSTALLED IN ACCORDANCE WITH THE CURRENT EDITION OF "NEW YORK STATE STANDARDS AND SPECIFICATIONS FOR EROSION AND SEDIMENT CONTROLS" (BLUE BOOK).

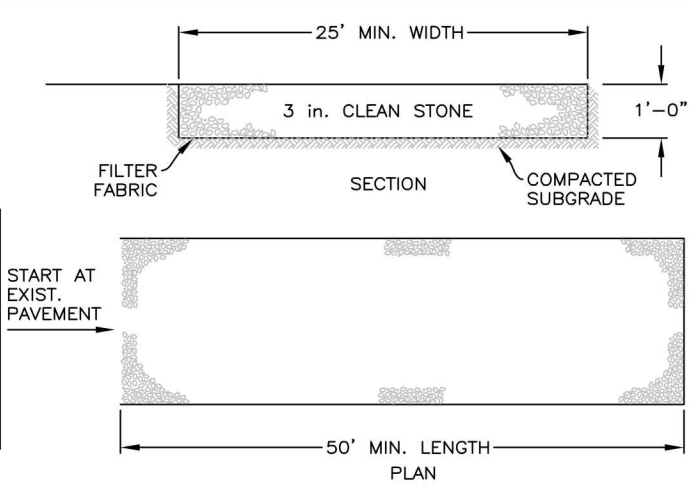

INSTALLATION NOTES

- STONE SIZE - USE 3" STONE, OR RECLAIMED OR RECYCLED CONCRETE EQUIVALENT.
- LENGTH AS REQUIRED, BUT NOT LESS THAN 50 FEET (EXCEPT ON A SINGLE RESIDENCE LOT WHERE A 30 FOOT MINIMUM LENGTH WOULD APPLY).
- THICKNESS - NOT LESS THAN SIX (6) INCHES.
- WIDTH - AS NOTED MINIMUM, BUT NOT LESS THAN THE FULL WIDTH AT POINTS WHERE INGRESS OR EGRESS OCCUR.
- FILTER CLOTH WILL BE PLACED OVER THE ENTIRE AREA PRIOR TO PLACING OF STONE. FILTER CLOTH WILL NOT BE REQUIRED ON A SINGLE FAMILY RESIDENCE LOT.
- SURFACE WATER - ALL SURFACE WATER FLOWING OR DIVERTED TOWARD CONSTRUCTION ENTRANCES SHALL BE PIPED ACROSS THE ENTRANCE, IF PIPING IS IMPRACTICAL, A MOUNTABLE BERM WITH 5:1 SLOPES WILL BE PERMITTED.
- MAINTENANCE - THE ENTRANCE SHALL BE MAINTAINED IN A CONDITION WHICH WILL PREVENT TRACKING OR FLOWING OF SEDIMENT ONTO PUBLIC RIGHT OF WAY THIS MAY REQUIRE PERIODIC TOP DRESSING WITH ADDITIONAL STONE AS CONDITIONS DEMAND AND REPAIR AND/OR CLEANOUT OF ANY MEASURES USED TO TRAP SEDIMENT. ALL SEDIMENT SPILLED, DROPPED, WASHED OR TRACKED ONTO PUBLIC RIGHT OF WAY MUST BE REMOVED IMMEDIATELY.
- WASHING - WHEELS SHALL BE CLEANED TO REMOVE SEDIMENT PRIOR TO ENTRANCE ONTO PUBLIC RIGHT OF WAY. WHEN WASHING IS REQUIRED, IT SHALL BE DONE IN AN AREA STABILIZED WITH STONE AND WHICH DRAINS INTO AN APPROVED SEDIMENT TRAPPING DEVICE. PERIODIC INSPECTION AND NEEDED MAINTENANCE SHALL BE PROVIDED AFTER EACH RAIN.

STABILIZED CONSTRUCTION ENTRANCE (ANTI-TRACKING PAD) N.T.S.

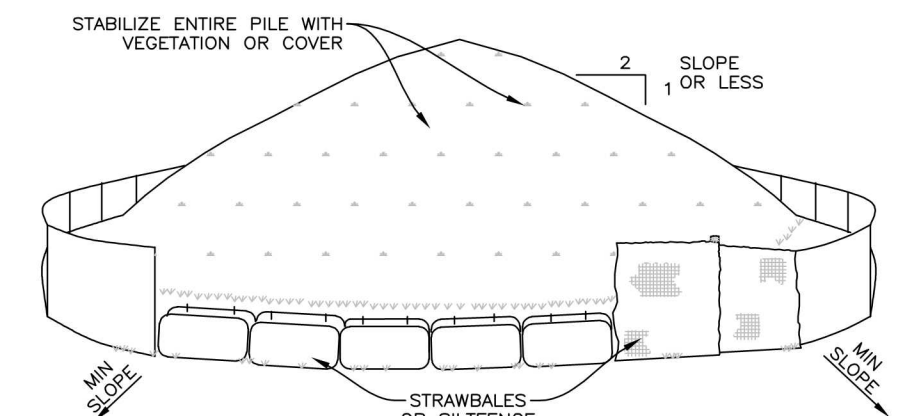

TO BE USED WHERE TOPSOIL PRESERVATION IS NECESSARY FOR REGRADING AND VEGETATING DISTURBED AREAS. TOPSOIL IS APPLIED TO SUBSOILS THAT ARE DROUGHTY (HAVING LOW AVAILABLE MOISTURE FOR PLANTS), STONY, SALTY, HAVE LOW PERMEABILITY, OR ARE EXTREMELY ACID. IT IS ALSO USED TO BACKFILL AROUND SHRUBS AND TREE TRANSPLANTS. PRESERVATION OF EXISTING TOPSOIL IS BENEFICIAL FOR ALL TYPES OF LAWN OR ORNAMENTAL PLANTINGS.

TEMPORARY STOCKPILE STABILIZATION MEASURES INCLUDE VEGETATIVE COVER, MULCH, NON-VEGETATIVE COVER, AND PERIPHERAL SEDIMENT TRAPPING BARRIERS. THE STABILIZATION MEASURE(S) SELECTED SHOULD BE APPROPRIATE FOR THE TIME OF YEAR, SITE CONDITIONS, AND REQUIRED DURATION OF USE.

INSTALLATION NOTES

- AREA CHOSEN FOR STOCKPILING OPERATIONS SHALL BE DRY AND STABLE.
- MAXIMUM SLOPE OF STOCKPILE SHALL BE 1:2.
- UPON COMPLETION OF SOIL STOCKPILING, EACH PILE SHALL BE SURROUNDED WITH EITHER SILT FENCING OR STRAWBALES, THEN STABILIZED WITH VEGETATION OR COVERED.

TEMPORARY MATERIAL STOCKPILE N.T.S.

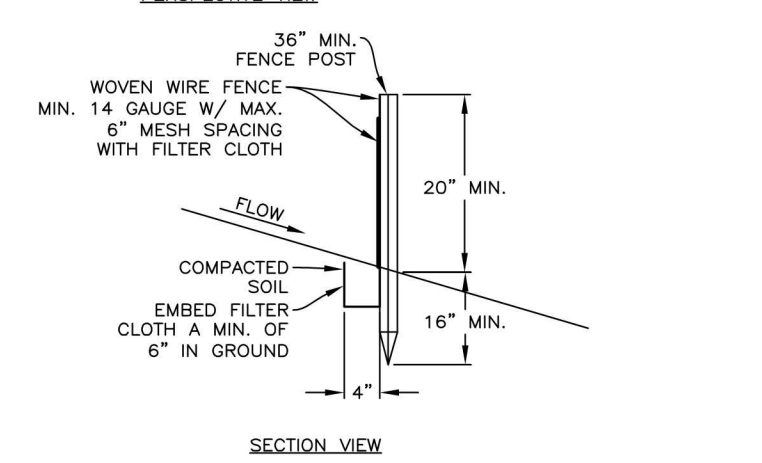
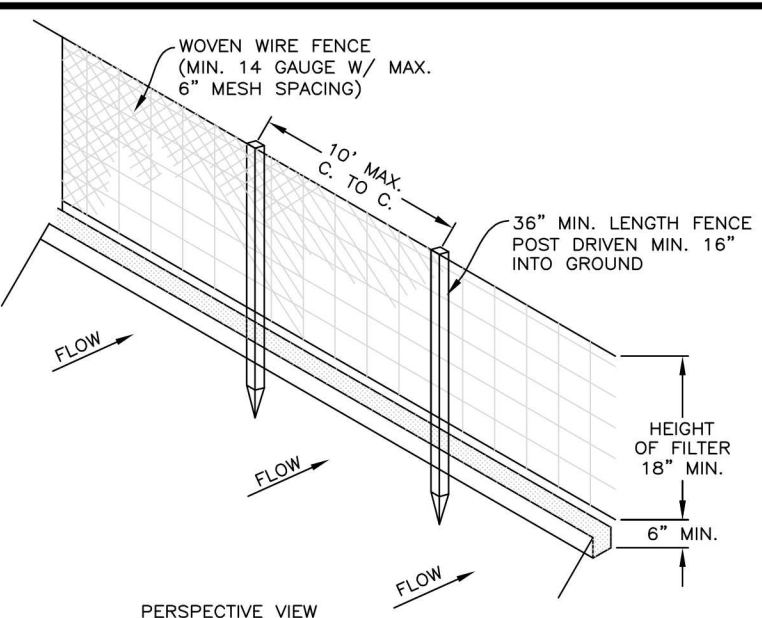
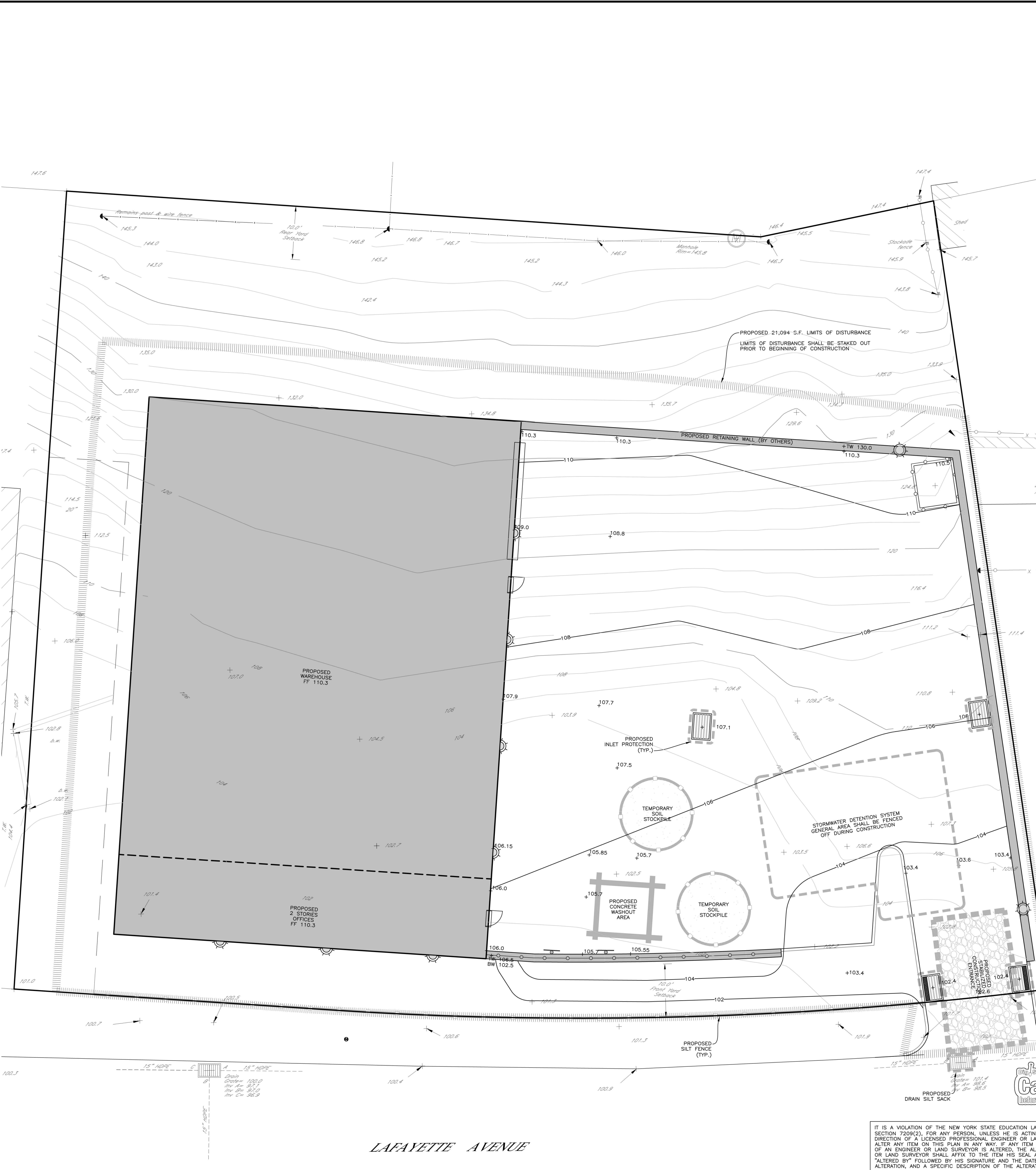

- CONSTRUCTION SPECIFICATIONS**
- WOVEN WIRE FENCE TO BE FASTENED SECURELY TO FENCE POST WITH TIES OR STAPLES. POST SHALL BE STEEL, EITHER "T" OR "U" TYPE OR HARDWOOD.
 - FILTER CLOTH TO BE FASTENED SECURELY TO WOVEN WIRE FENCE WITH TIES SPACED EVERY 24" AT TOP AND MID SECTION. FENCE SHALL BE WOVEN WIRE, 6" MAXIMUM MESH OPENING.
 - WHEN TWO SECTIONS OF FILTER CLOTH ADJOIN EACH OTHER THEY SHALL BE OVERLAPPED BY SIX INCHES AND FOLDED. FILTER CLOTH SHALL BE EITHER FILTER X, MIRAFI 100X, STABILINKA T140N, OR APPROVED EQUIVALENT.
 - PREFABRICATED UNITS SHALL MEET THE MINIMUM REQUIREMENTS SHOWN.
 - MAINTENANCE SHALL BE PERFORMED AS NEEDED AND MATERIAL REMOVED WHEN "BULGES" DEVELOP IN THE SILT FENCE.

CONSTRUCTION SEQUENCE:

THE CONSTRUCTION WILL BE IN A SEQUENCE THAT WILL MINIMIZE THE POTENTIAL FOR EROSION. CONSTRUCTION IS ANTICIPATED TO BEGIN IN FALL 2023 AND BE COMPLETED BY FALL 2025.

THE GENERAL SEQUENCE OF CONSTRUCTION IS AS FOLLOWS:

- PRE-CONSTRUCTION MEETING, STAKEOUT, EROSION CONTROL MEASURES, CLEARING.
- PRE-CONSTRUCTION MEETING, STAKEOUT, EROSION CONTROL MEASURES, CLEARING.
 - A PRE-CONSTRUCTION MEETING WILL TAKE PLACE WITH THE TOWN ENGINEER, APPLICANT, APPLICANT'S REPRESENTATIVE, UTILITY COMPANY AND CONTRACTORS.
 - THE INITIAL FIELDWORK SHALL CONSIST OF SURVEYING AND STAKING FOR DISTURBANCE LIMITS AND EROSION CONTROL INSTALLATION.
 - THE PLACEMENT OF A CONSTRUCTION TRAILER AND/OR FIELD OFFICE AND A CONSTRUCTION STAGING AREA, IF NECESSARY SHALL COMMENCE.
 - ALL TREES TO BE PRESERVED WITHIN THE DISTURBANCE LIMITS SHALL BE MARKED AND PROTECTED PRIOR TO THE START OF CLEARING OPERATIONS.
 - EROSION CONTROLS SHALL BE INSTALLED AS SHOWN ON THE EROSION CONTROL PLAN AND AS PER THE RESPECTIVE EROSION CONTROL DETAILS PER THE CONSTRUCTION SEQUENCE.
 - SILT FENCE AND HAYBALES, WHERE INDICATED, SHALL BE INSTALLED.
 - ANTI-TRACKING PADS SHALL BE INSTALLED AT ALL CONSTRUCTION ENTRANCES.
 - TREES TO BE REMOVED SHALL BE CUT AT THIS TIME.
 - TREE STUMPS SHALL BE REMOVED AT THIS TIME. TREE STUMP REMOVAL SHALL ONLY INCLUDE STUMPS WITHIN THE IMMEDIATE WORK AREA. SILT FENCE DAMAGED BY TREE STUMP REMOVAL SHALL BE REPLACED.
 - DEMOLITION AND EARTHWORK
 - INSTALL STRAW BALES AND SILT FENCE.
 - CLEAR AND GRUB FOR REMAINING WORK AREA.
 - SOIL STRIPPING AND STOCKPILING OCCUR AT THIS TIME.
 - AFTER SILT FENCE AND HAYBALES HAVE ALL BEEN INSTALLED PRELIMINARY EARTHWORK OPERATIONS SHALL BEGIN.
 - BUILDING CONSTRUCTION/GRADING/DRAINAGE/SYSTEM INSTALLATION/UTILITY INSTALLATION
 - BUILDING EXCAVATION FOR THE FOOTINGS AND THE FOUNDATIONS SHALL BEGIN.
 - THE BUILDING'S SUPERSTRUCTURE CONSTRUCTION BEGINS ONCE THE FOUNDATIONS HAVE PROPERLY CURED AND BACKFILLING IS COMPLETE.
 - UTILITIES SUCH AS DRAINAGE, SEWER CONNECTION, AND ELECTRIC ALONG WITH OTHERS, AS REQUIRED, SHALL BE INSTALLED, BACKFILLED AND COMPACTED WHILE THE SUPERSTRUCTURE IS BEING BUILT.
 - BEFORE THE DRAINAGE SYSTEM IS INSTALLED A DEEP AND PERCOLATION TEST SHALL BE PERFORMED. ALSO IT SHALL BE PROTECTED TO ENSURE SEDIMENT DOES NOT ENTER THE SYSTEM. DRAIN INLETS AND CATCH BASINS SHALL BE RAISED APPROXIMATELY 3" ABOVE FINISHED GRADE DURING CONSTRUCTION, PRIOR TO PAVING, AND PRIOR TO BINDER COURSE INSTALLATION.
 - THE INFILTRATION SYSTEM SHALL BE INSTALLED AND PROTECTED FROM HEAVY MACHINERY.
 - THE APPROPRIATE PROPOSED UTILITY SERVICES ARE INSTALLED TO THE PROPOSED BUILDING.
 - ONCE ROUGH GRADING OPERATIONS ARE COMPLETED, FINAL GRADING WILL COMMENCE AND BINDER COURSE WILL BE INSTALLED. AFTER BINDER COURSE IS INSTALLED, INLET PROTECTION SHALL BE PAVED SURFACE INSTALLATION.
 - SEEDING, SOODING, AND OTHER SOIL STABILIZING LANDSCAPING MAY BE INSTALLED.
 - THE INFILTRATION SYSTEMS SHALL NOT BE PUT INTO SERVICE UNTIL THE TRIBUTARY AREA IS STABILIZED.
 - STABILIZATION
 - ROADWAYS/PARKING AREAS SHALL BE PAVED WITH TOP COURSE AND STRIPPED AS HEAVY EQUIPMENT IS NO LONGER REQUIRED ON-SITE.
 - REMOVAL OF EROSION CONTROL DEVICES
 - AS AREAS ARE STABILIZED, SEDIMENT SHALL BE REMOVED AND EROSION CONTROL DEVICES SHALL BE DISCARDED IN AN APPROPRIATE MANNER. FINAL STABILIZATION FOR VEGETATED AREAS REQUIRES AT LEAST 80% VEGETATIVE COVER. ALL DRAINAGE STRUCTURES SHALL BE INSPECTED AND CLEANED IF NECESSARY.

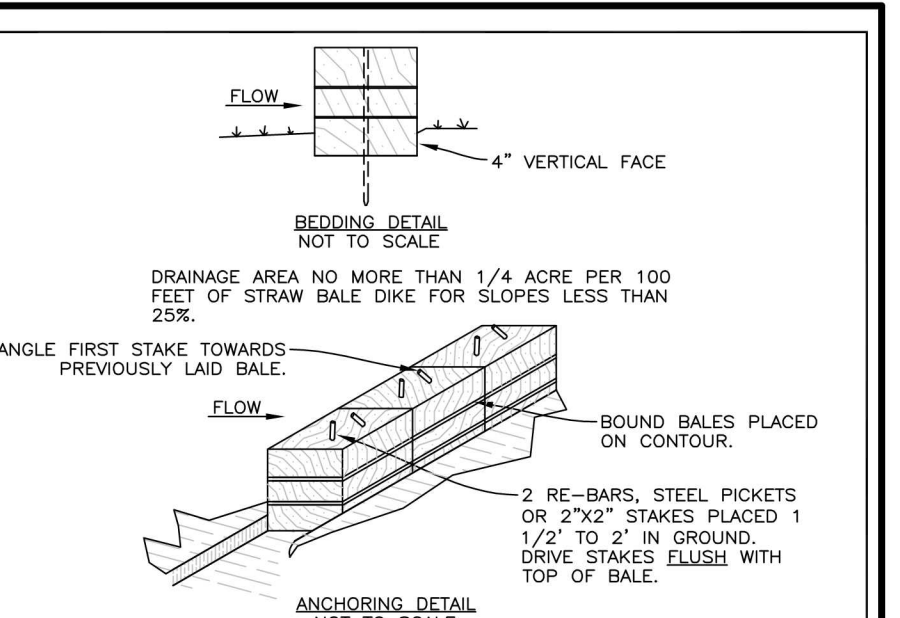

- CONSTRUCTION SPECIFICATIONS**
- BALES SHALL BE PLACED AT THE TOE OF A SLOPE OR ON THE CONTOUR AND IN A ROW WITH ENDS TIGHTLY ADJUTING THE ADJACENT BALES.
 - EACH BALE SHALL BE EMBEDDED IN THE SOIL A MINIMUM OF (4) INCHES, AND PLACED SO THE BINDINGS ARE HORIZONTAL.
 - BALES SHALL BE SECURELY ANCHORED IN PLACE BY EITHER TWO STAKES OR RE-BARS DRIVEN THROUGH THE BALE. THE FIRST STAKE IN EACH BALE SHALL BE DRIVEN TOWARD THE PREVIOUSLY LAID BALE AT AN ANGLE TO FORCE THE BALES TOGETHER. STAKES SHALL BE DRIVEN FLUSH WITH THE BALE.
 - INSPECTION SHALL BE FREQUENT AND REPAIR REPLACEMENT SHALL BE MADE PROMPTLY AS NEEDED.
 - BALES SHALL BE REMOVED WHEN THEY HAVE SERVED THEIR USEFULNESS SO AS NOT TO BLOCK OR IMPEDE STORM FLOW OR DRAINAGE.

HAYBALE SEDIMENT BARRIERS N.T.S.

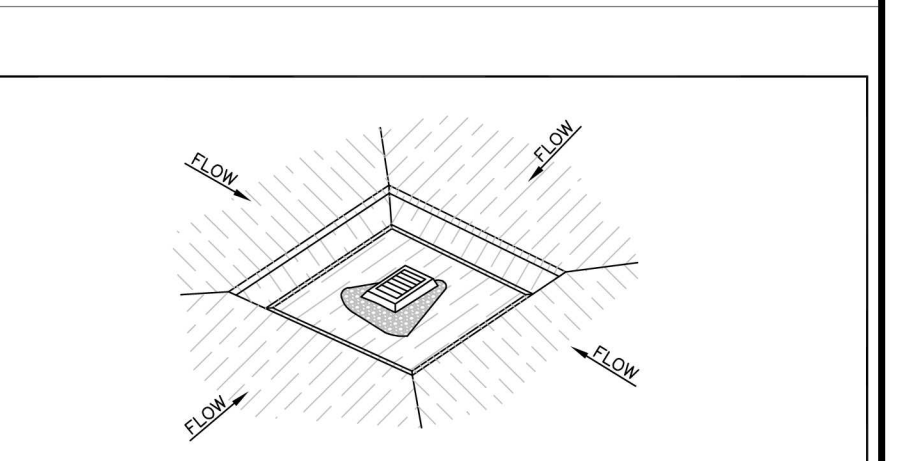

- CLEAR THE AREA OF ALL DEBRIS THAT WILL HINDER EXCAVATION.
- GRADE APPROACH TO BE PROTECTED BY GRAVEL.
- WEEP HOLES SHALL BE PROTECTED BY GRAVEL.
- UPON STABILIZATION OF CONTRIBUTING DRAINAGE AREA, SEAL WEEP HOLES, FILL BASIN WITH STABLE SOIL TO FINAL GRADE, COMPACT IT PROPERLY AND STABILIZE WITH PERMANENT SEEDING. MAXIMUM DRAINAGE AREA 1 ACRE

INLET PROTECTION N.T.S.

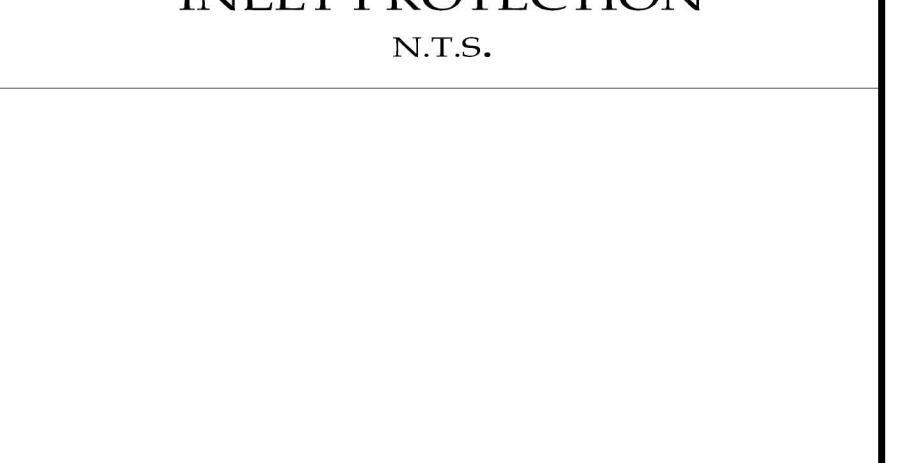

U.S. DEPARTMENT OF AGRICULTURE
NATURAL RESOURCES CONSERVATION SERVICE
NEW YORK STATE DEPARTMENT OF ENVIRONMENTAL CONSERVATION
NEW YORK STATE SOIL & WATER CONSERVATION COMMITTEE

ALFONZETTI ENGINEERING, P.C.
14 SMITH AVE, MT. KISCO, N.Y. 10549
914-666-9800 INFO@ALFONZETTIENG.COM

STATE OF NEW YORK
RALPH ALFONZETTI
LICENSED PROFESSIONAL ENGINEER

SCALE: 1" = 10'

ALFONZETTI ENGINEERING, P.C.
14 SMITH AVE, MT. KISCO, N.Y. 10549
914-666-9800 INFO@ALFONZETTIENG.COM

SITE DATA

OWNER/APPLICANT: 2012 MARIA MARTINS IRREVOCABLE TRUST
SITE ADDRESS: 78 LAFAYETTE AVE, NORTH WHITE PLAINS, NY 10603
TAX MAP #: 12212-1-29
LOT AREA: 0.6115 AC
ZONING: IND-A
DRAWING: SOIL AND EROSION CONTROL PLAN
REVISIONS: REVISED: JUNE 8, 2023
REVISED: DECEMBER 12, 2022

DATE: _____
CHRISTOPHER CARTHAY, CHAIRMAN
TOWN OF NORTH CASTLE PLANNING BOARD

DATE: _____
JOSEPH M. CERMELE, P.E.
KELLARD SESSIONS CONSULTING
CONSULTING TOWN ENGINEER

IT IS A VIOLATION OF THE NEW YORK STATE EDUCATION LAW, ARTICLE 145, SECTION 7209(2), FOR ANY PERSON, UNLESS HE IS ACTING UNDER THE DIRECTION OF A LICENSED PROFESSIONAL ENGINEER OR LAND SURVEYOR, TO ALTER ANY ITEM ON THIS PLAN IN ANY WAY, IF ANY ITEM BEARING THE SEAL OF AN ENGINEER OR LAND SURVEYOR IS ALTERED, THE ALTERING ENGINEER OR LAND SURVEYOR SHALL AFFIX TO THE ITEM HIS SEAL AND THE NOTATION "ALTERED BY" FOLLOWED BY HIS SIGNATURE AND THE DATE OF SUCH ALTERATION, AND A SPECIFIC DESCRIPTION OF THE ALTERATION.

78 LAFAYETTE AVENUE
TOWN OF NORTH CASTLE,
WESTCHESTER COUNTY, NEW YORK

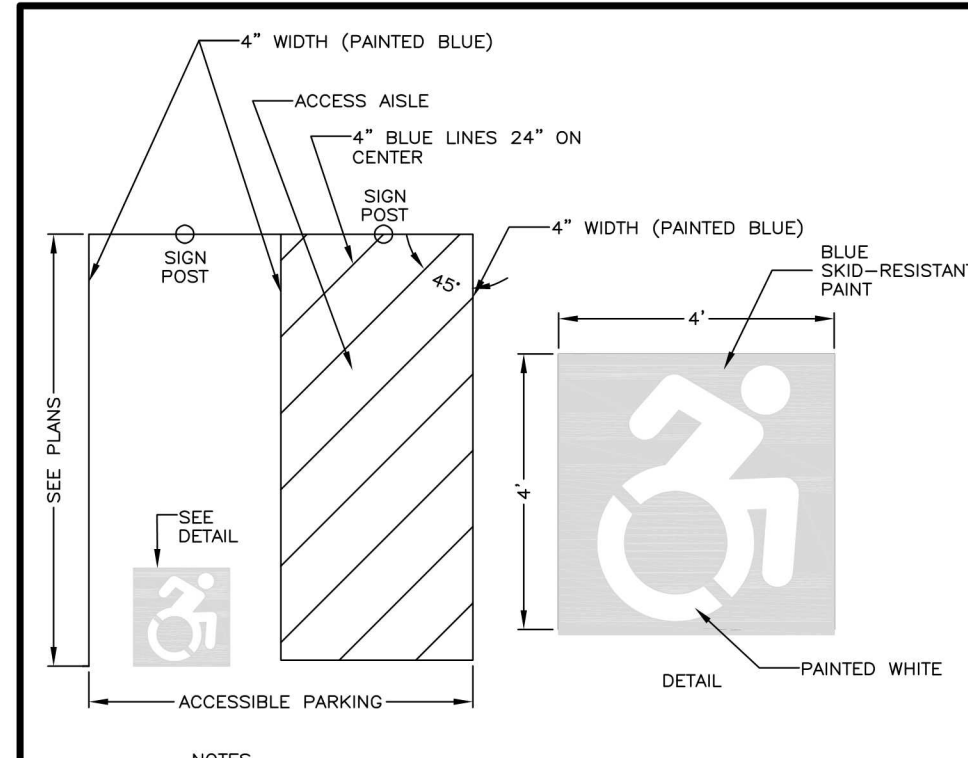

ACCESSIBLE PARKING SPACE
N.T.S.

NOTES:
1. ALL DIMENSIONS TO CENTER OF PAVEMENT STRIPING.
2. ALL SLOPES THROUGHOUT THE ACCESSIBLE PARKING AND AISLE AREAS SHALL NOT EXCEED 2.0%.
3. THE ACCESSIBLE SYMBOL DEPICTED ABOVE DOES NOT COMPLY WITH THE AMERICANS WITH DISABILITIES ACT (ADA) AND IS SHOWN FOR COMPLIANCE WITH STATE AND LOCAL REGULATIONS ONLY.

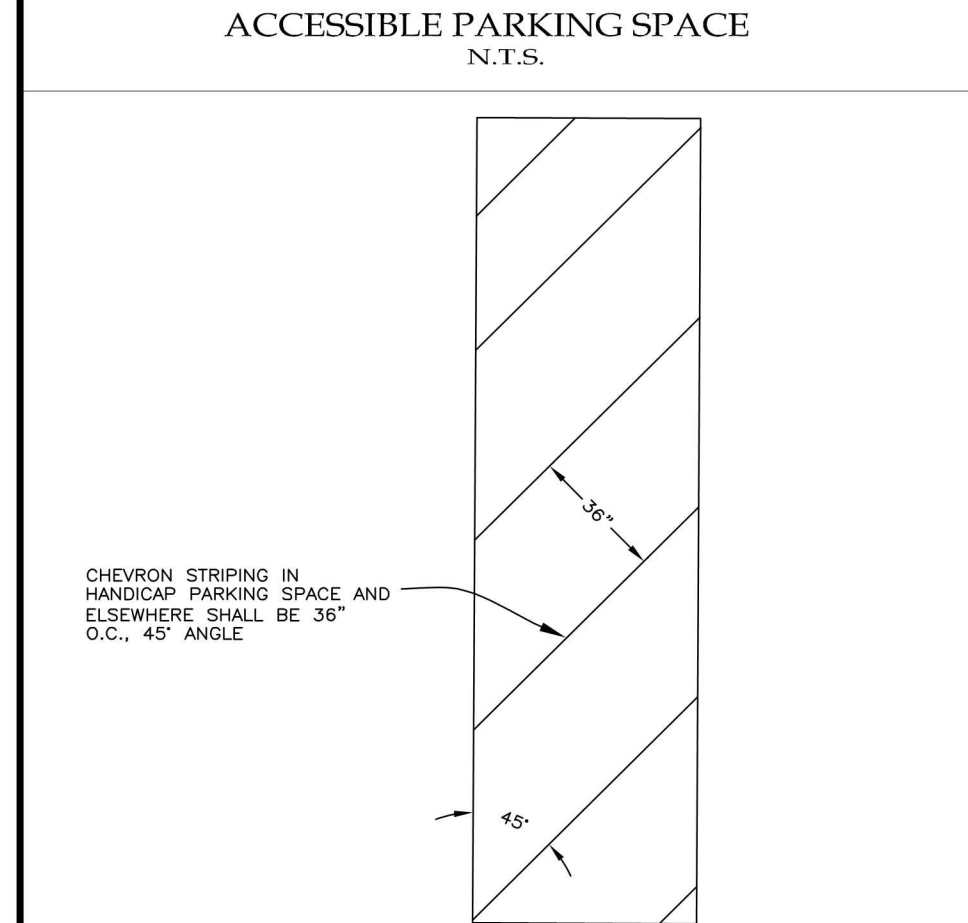

PAVEMENT MARKING DETAIL
N.T.S.

NOTES:
1. PARKING LOT STRIPING AND CHEVRONS SHALL BE 4" WIDE WHITE REFLECTIVE PAINT.
2. PARKING LOT STRIPING AND CHEVRONS IN DESIGNATED HANDICAP AISLE SHALL BE 4" WIDE BLUE REFLECTIVE PAINT.



ACCESSIBLE PARKING ONLY SIGN DETAIL
N.T.S.

12"x18" BLUE BACKGROUND WHITE BORDER WHITE SYMBOL WHITE TEXT BORDER: 3/8" 2" LETTERING



NO PARKING ANY TIME SIGN DETAIL
N.T.S.

NO PARKING ANYTIME SIGN MUTCD SIGN - R7-1
12"x18" WHITE BACKGROUND RED BORDER RED TEXT
LINE 1: 3" LETTERING
LINE 2: 3" LETTERING
LINE 3: 2" LETTERING
MARGIN: 3/8" BORDER: 3/8"

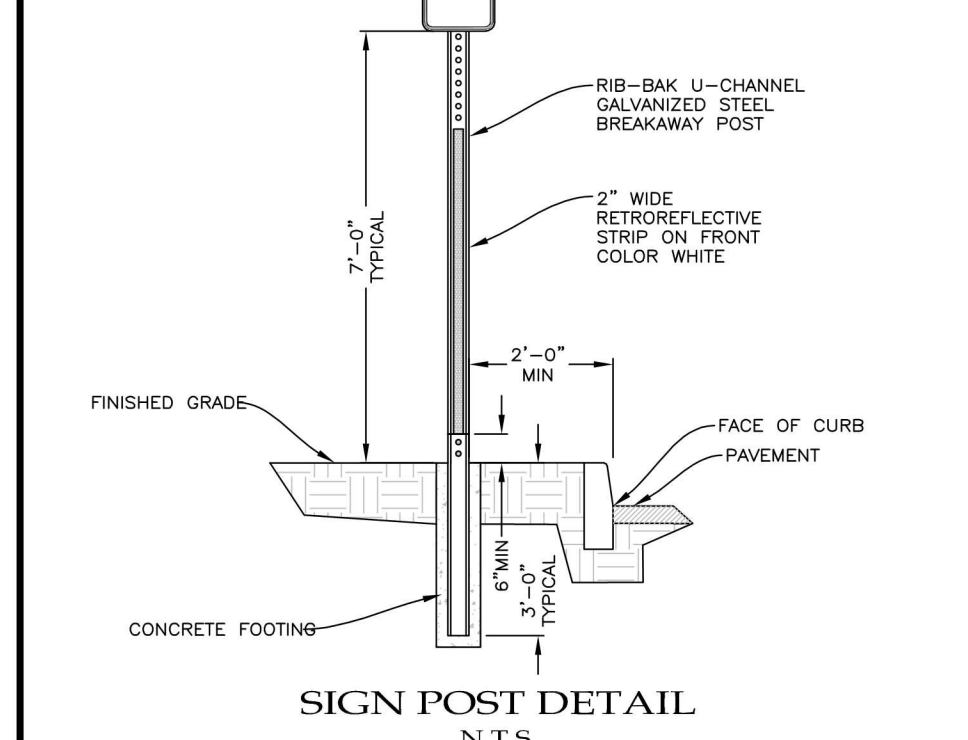

SIGN POST DETAIL
N.T.S.

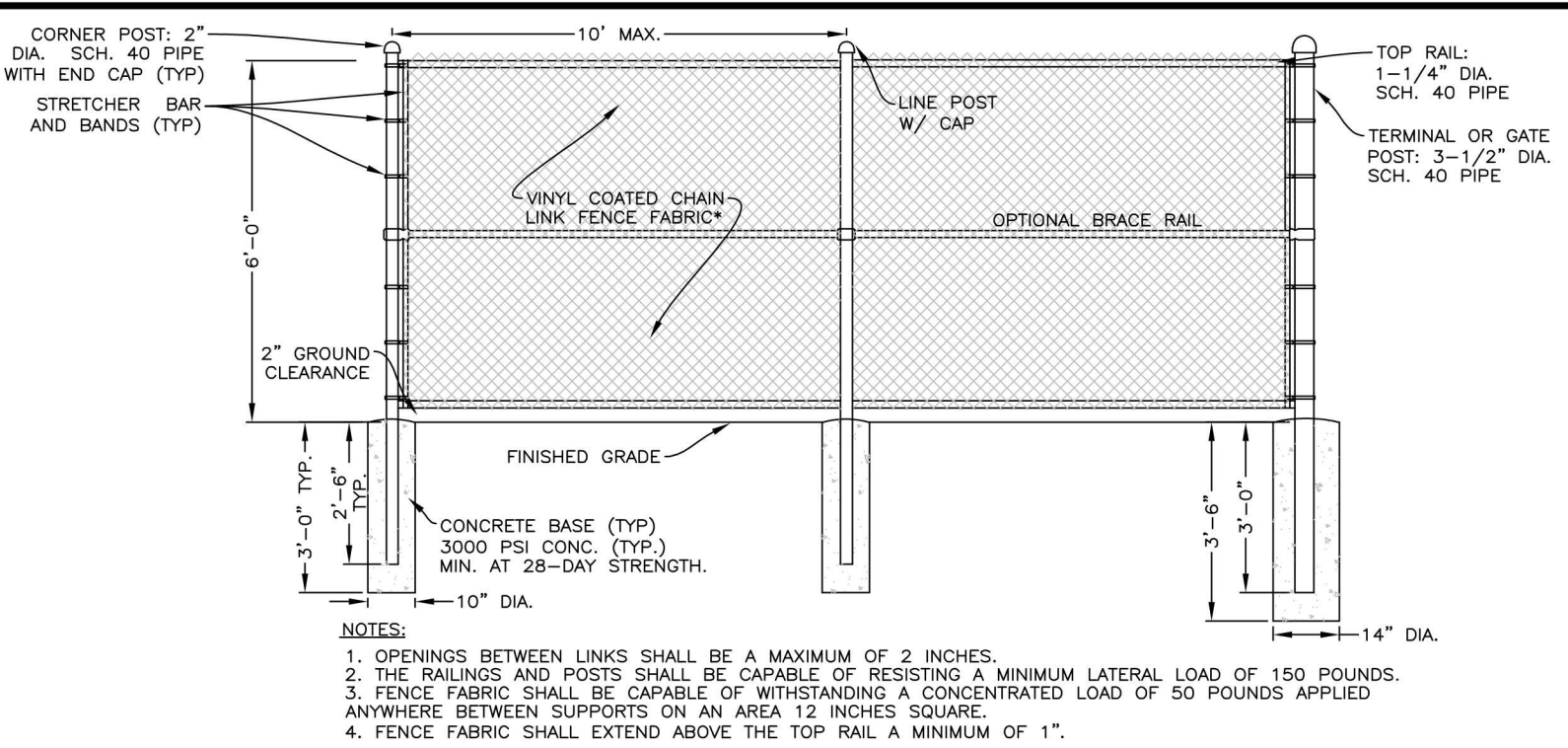

CHAIN LINK FENCE DETAIL (GARBAGE ENCLOSURE)
N.T.S.

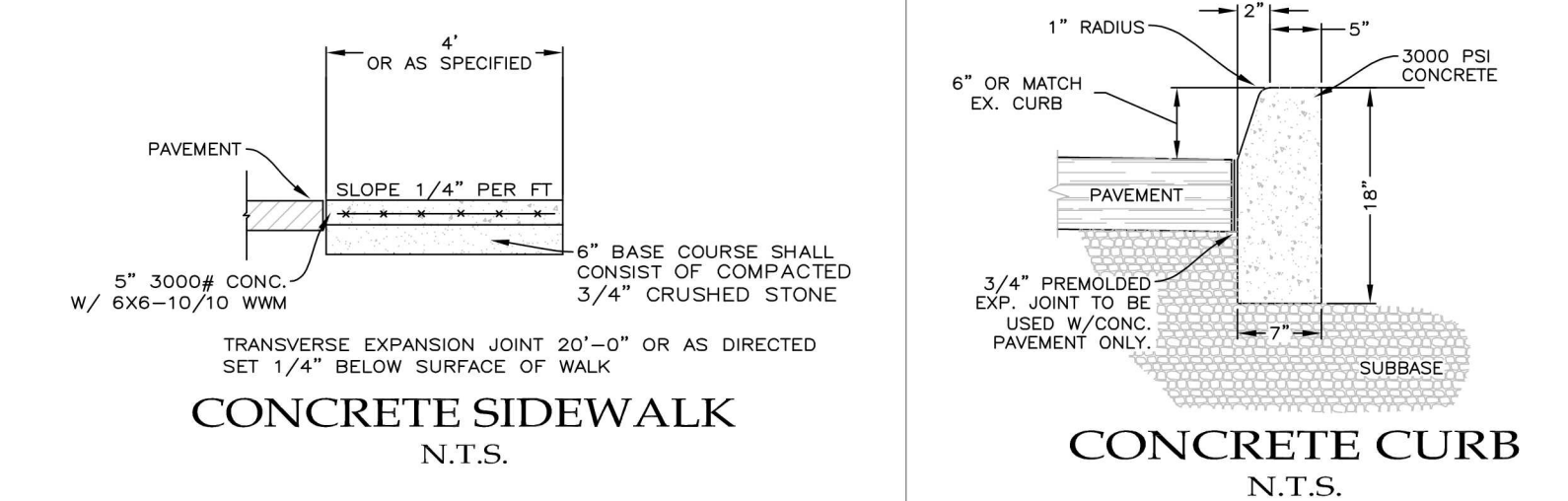

CONCRETE SIDEWALK
N.T.S.

CONCRETE CURB
N.T.S.

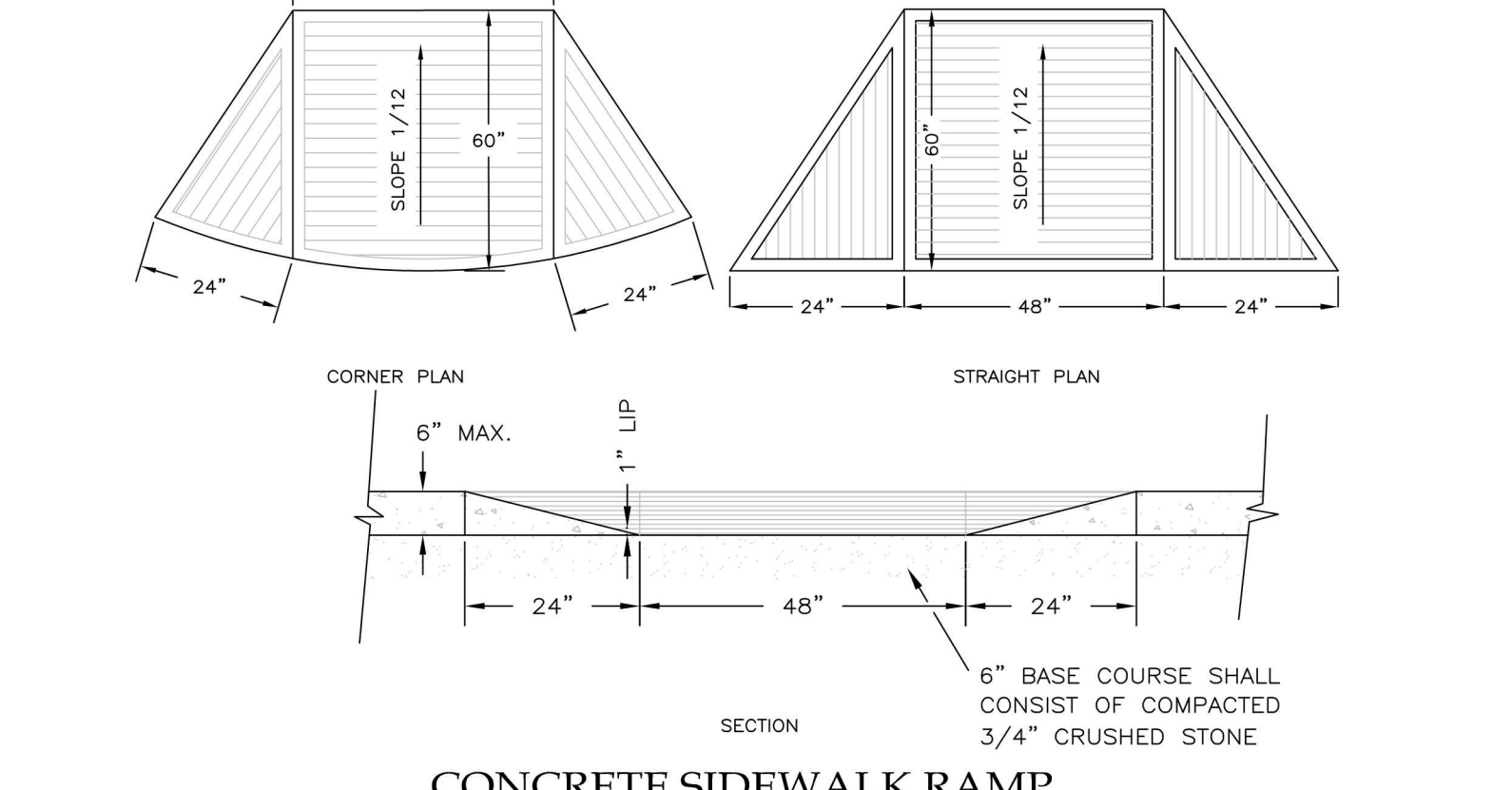

CONCRETE SIDEWALK RAMP
N.T.S.

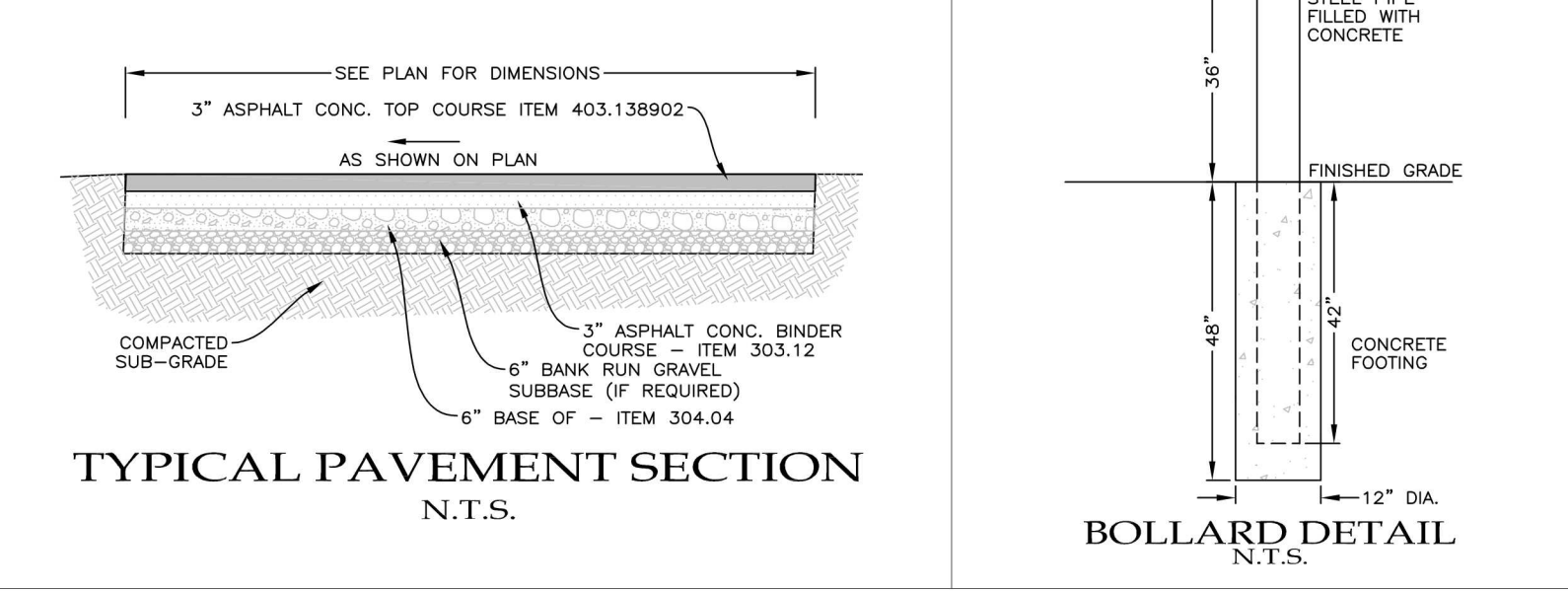

TYPICAL PAVEMENT SECTION
N.T.S.

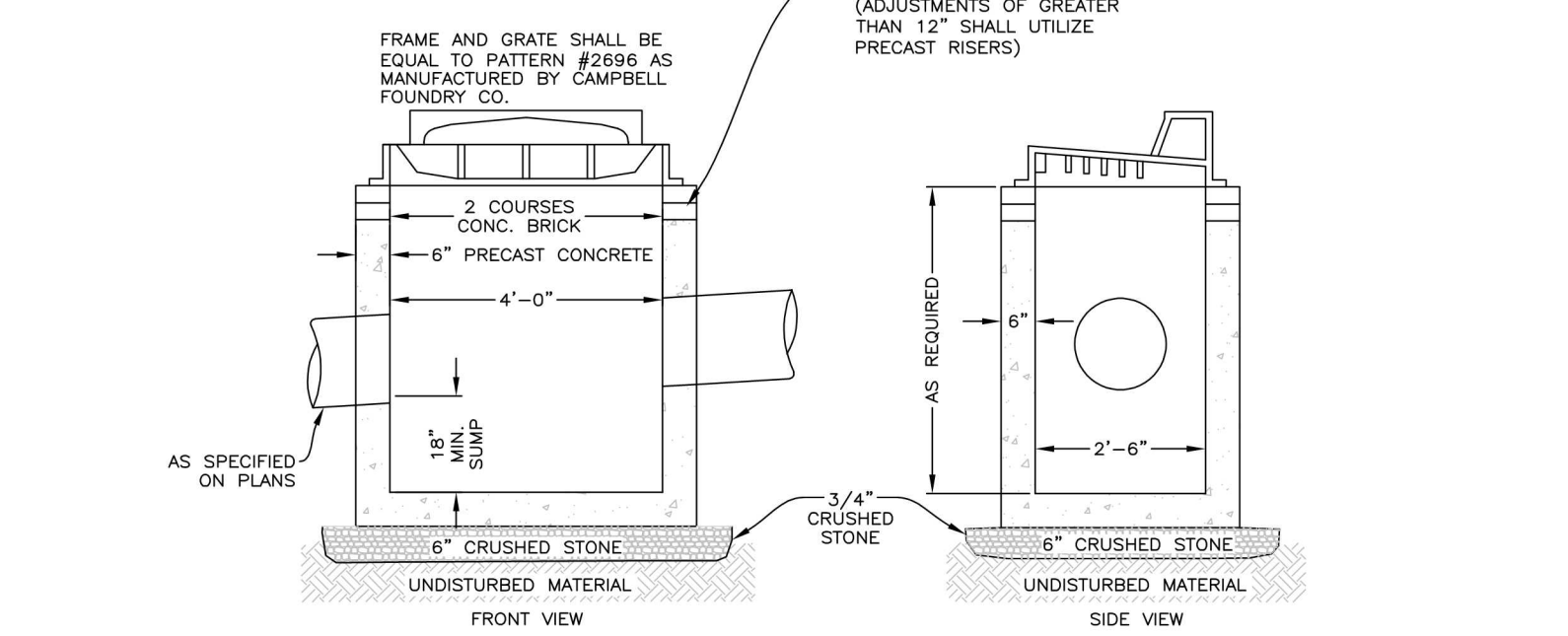

CATCH BASIN
N.T.S.

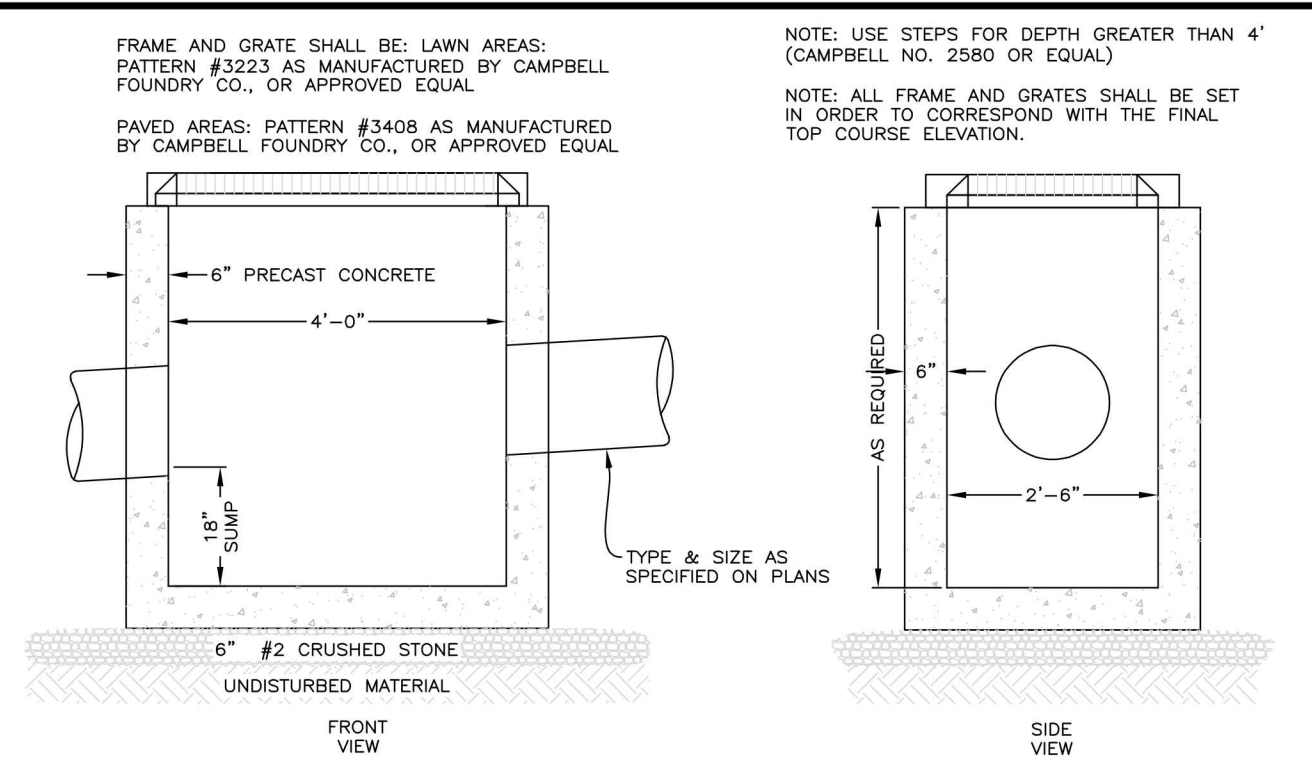

DRAIN INLET
N.T.S.

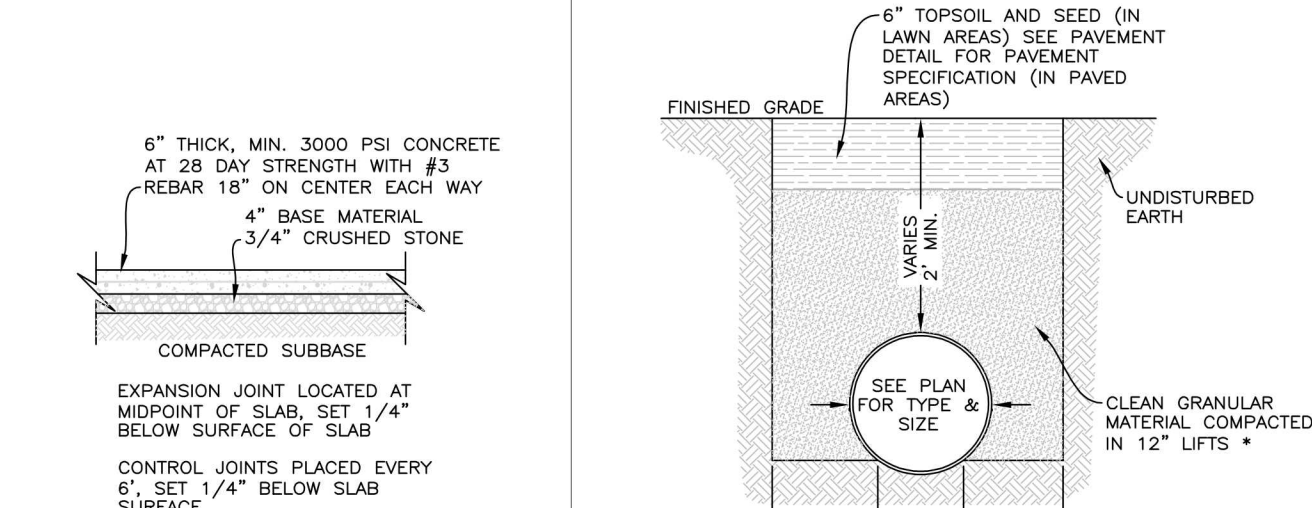

GARBAGE AREA PAD
N.T.S.

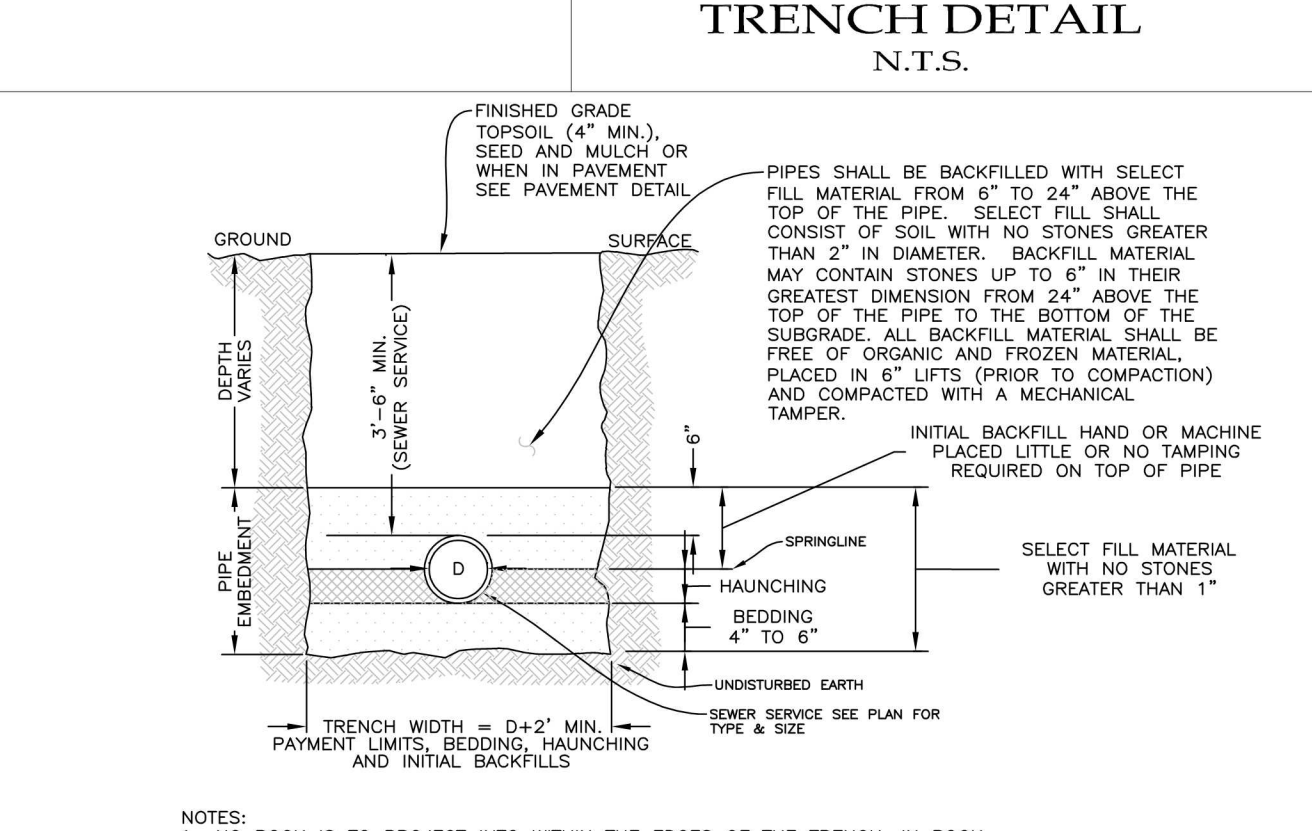

DRAIN PIPE TRENCH DETAIL
N.T.S.

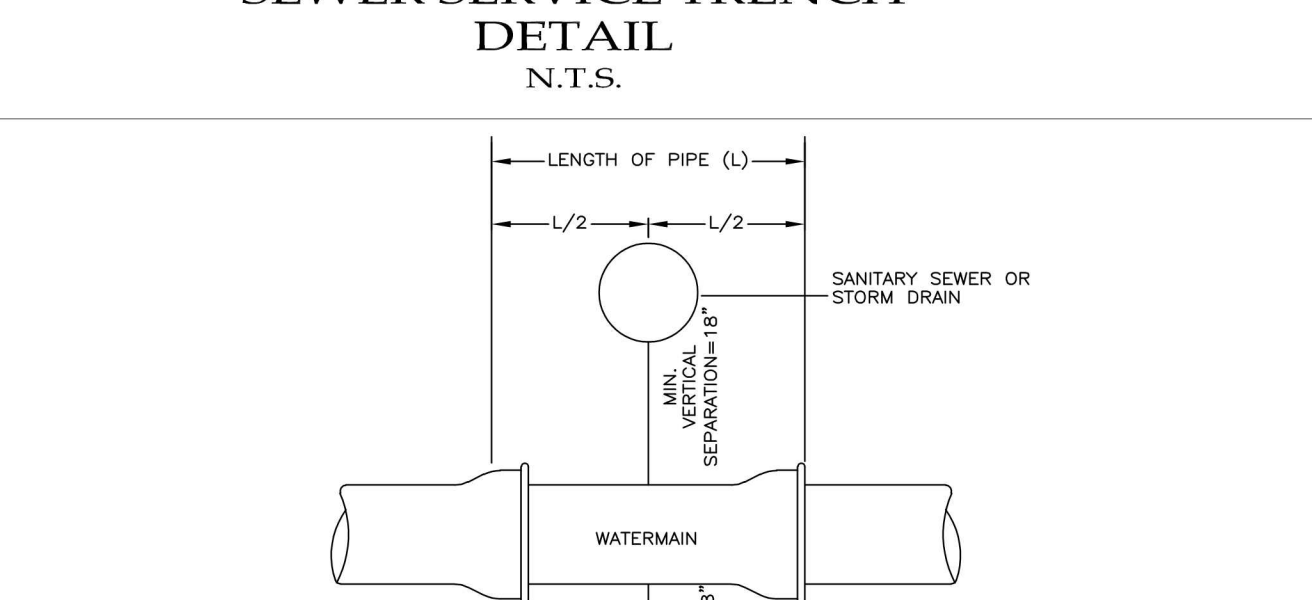

SEWER SERVICE TRENCH DETAIL
N.T.S.

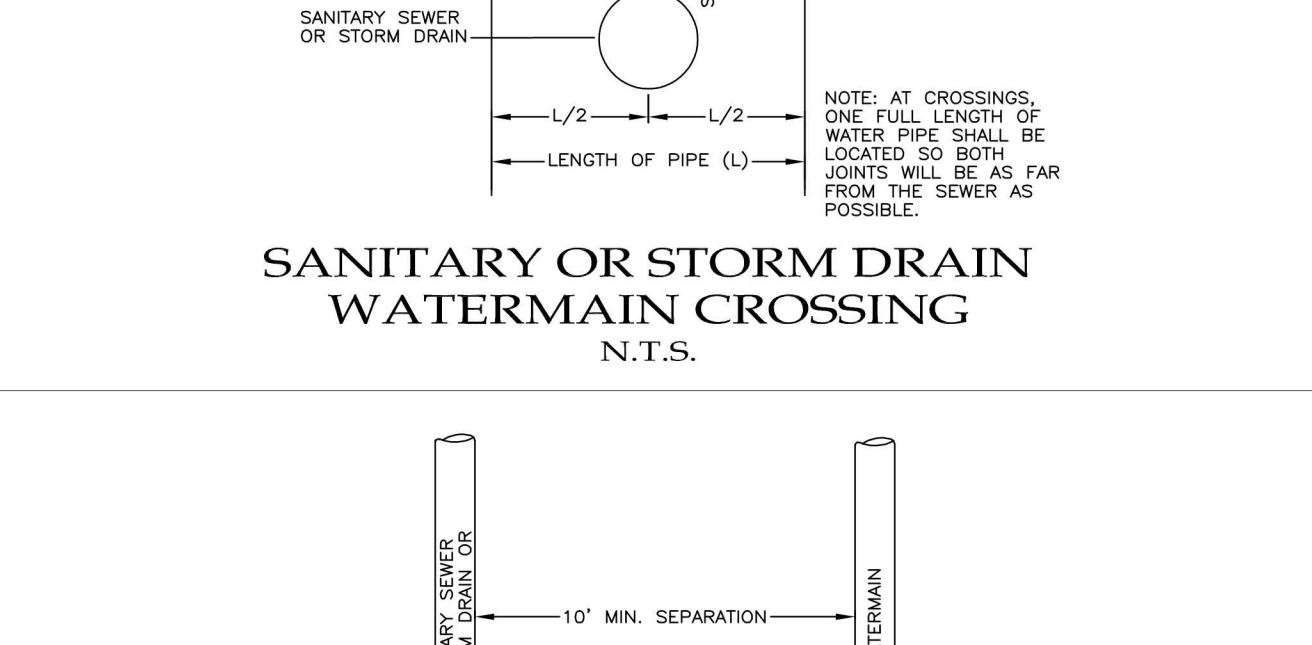

SANITARY OR STORM DRAIN WATERMAIN CROSSING
N.T.S.



WATER/UTILITY SEPARATION DETAIL
N.T.S.

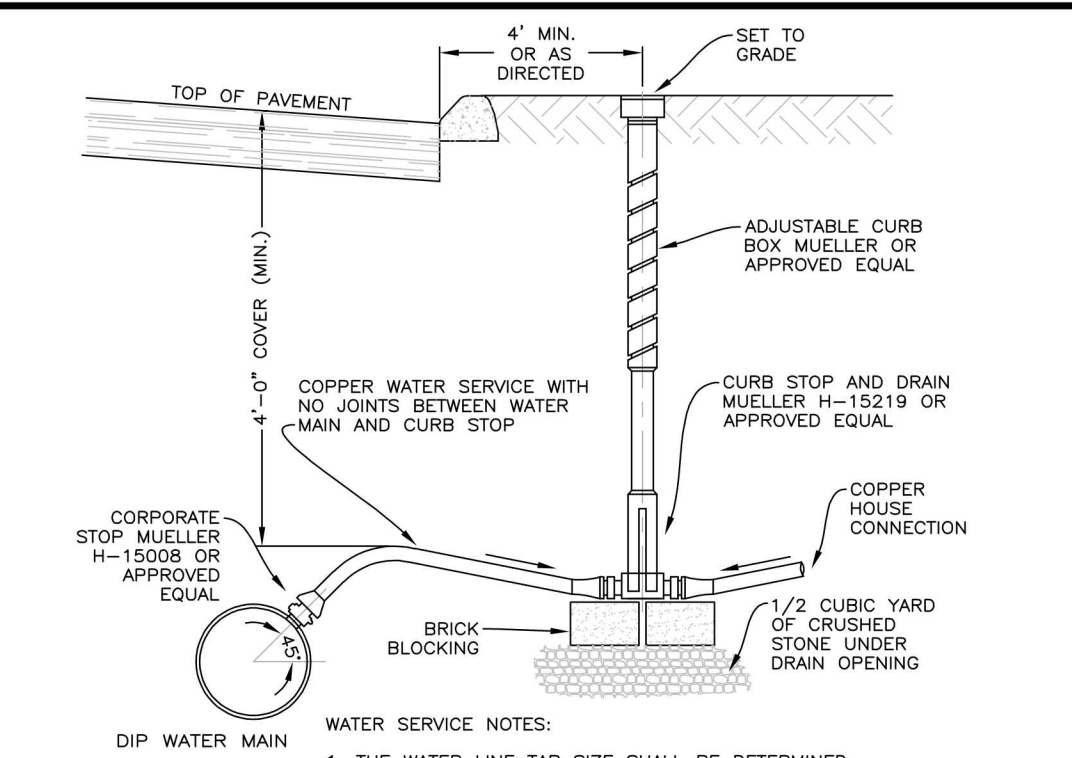

WATER SERVICE CONNECTION DETAIL
N.T.S.

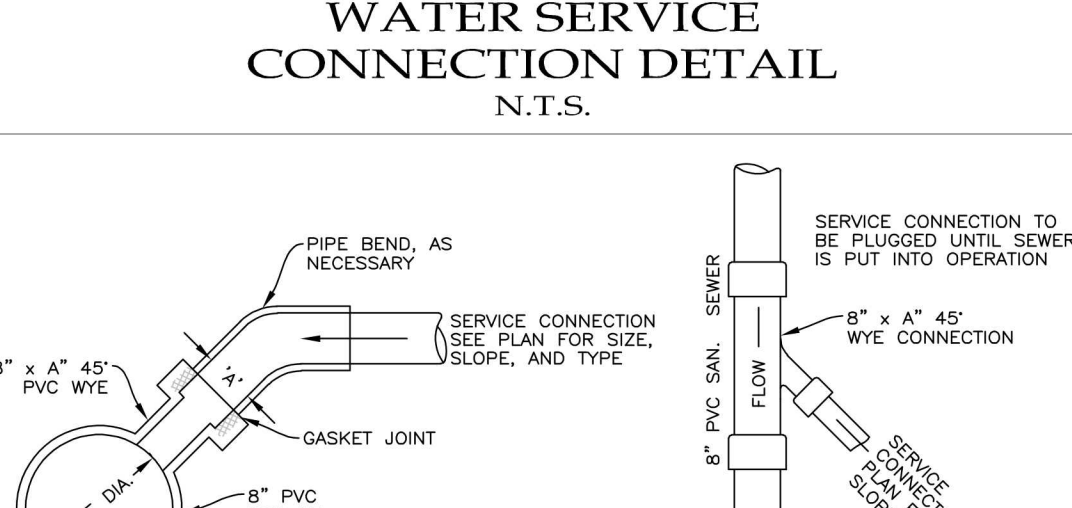

SEWER CONNECTION FOR PVC PIPE
N.T.S.

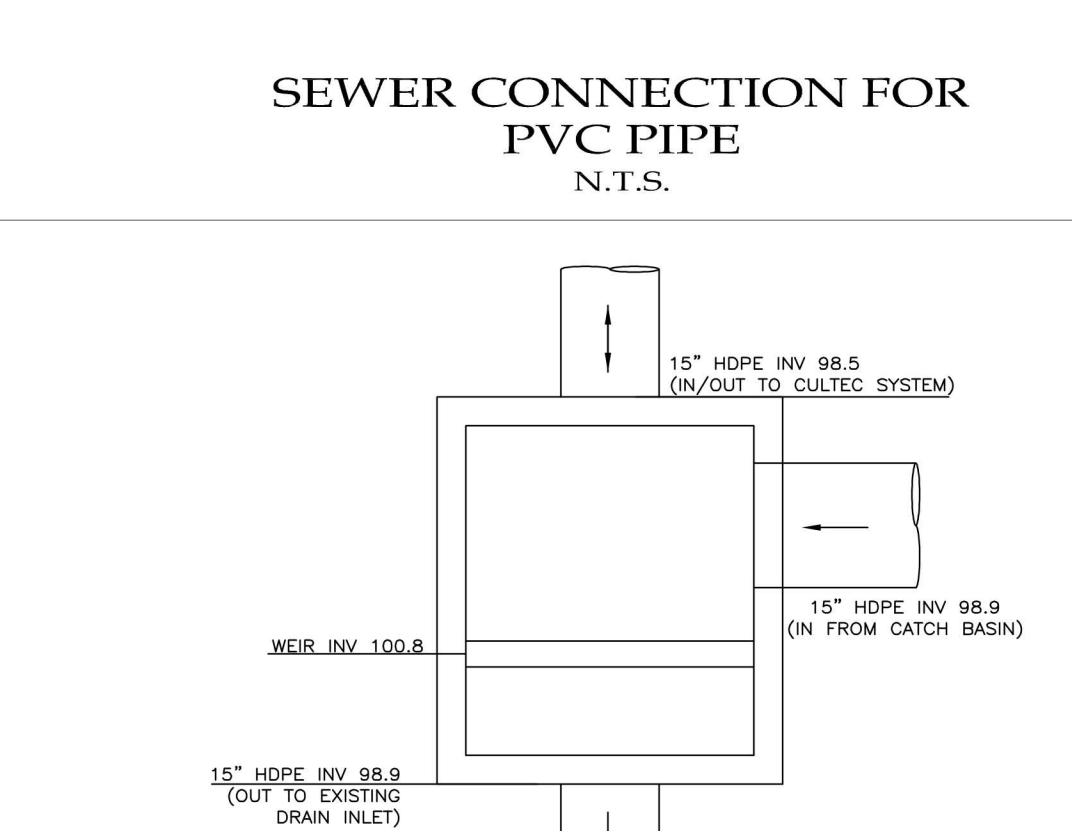

CONTROL STRUCTURE DETAIL
N.T.S.

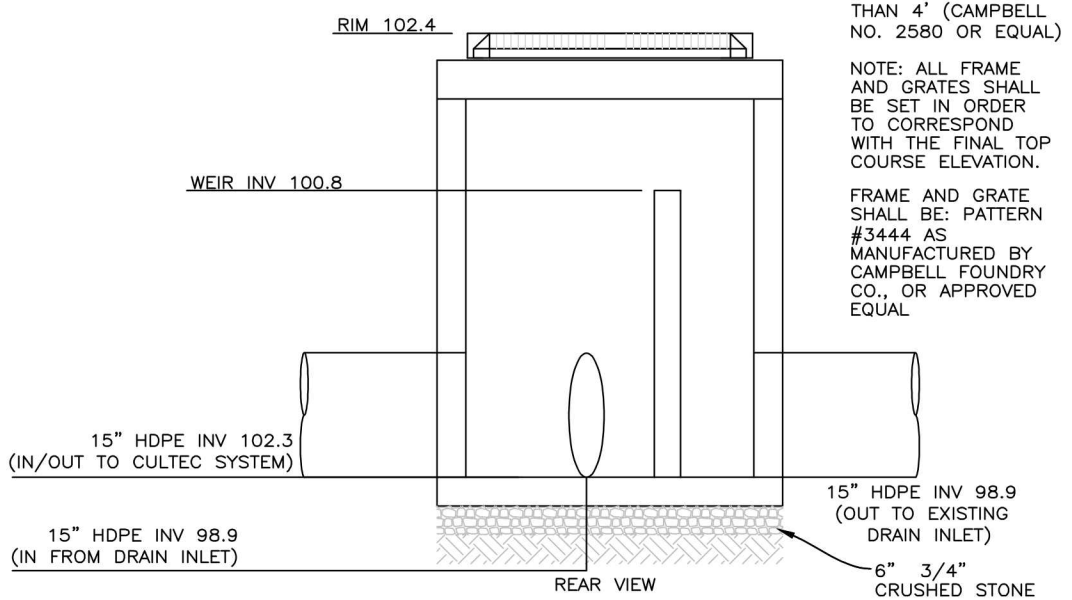

'CULTEC' CHAMBERS INSPECTION PORT TRAFFIC APPLICATION
N.T.S.

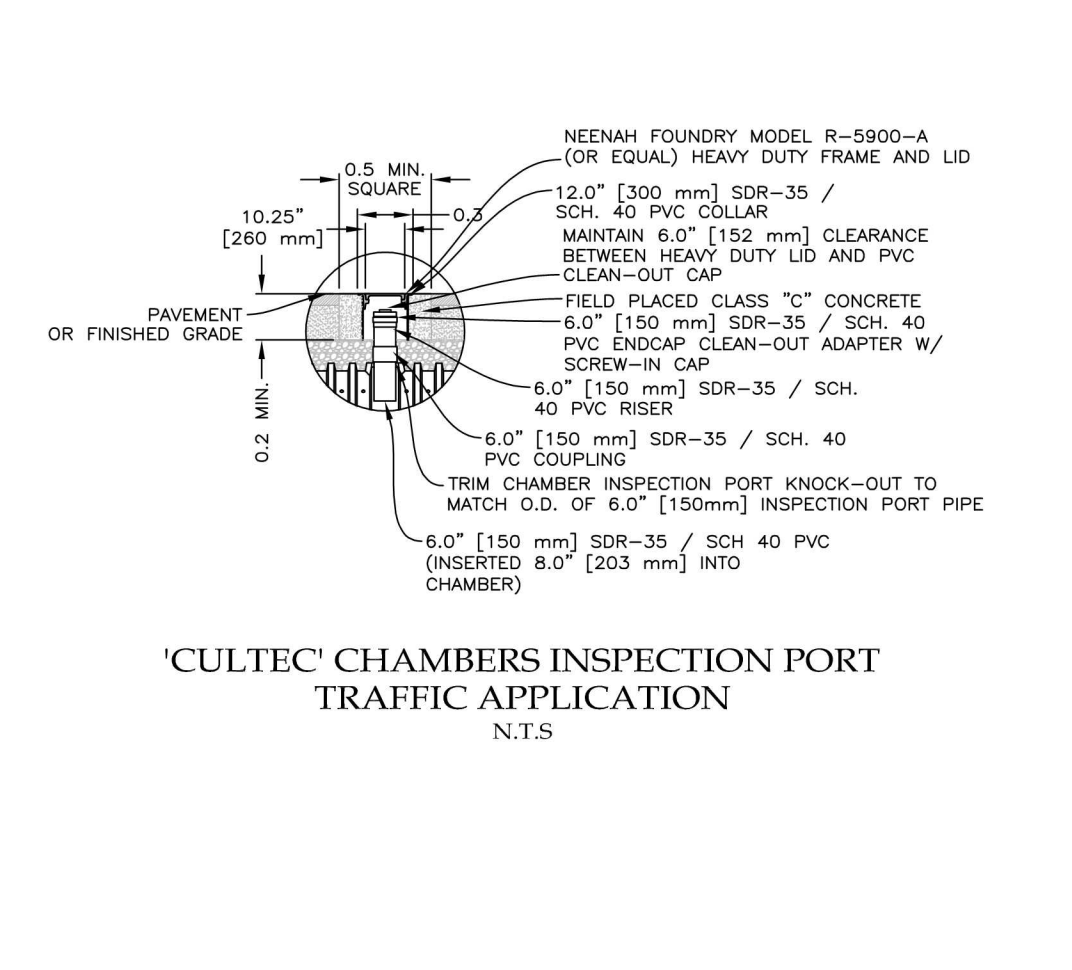

'CULTEC' CHAMBERS INSPECTION PORT TRAFFIC APPLICATION
N.T.S.

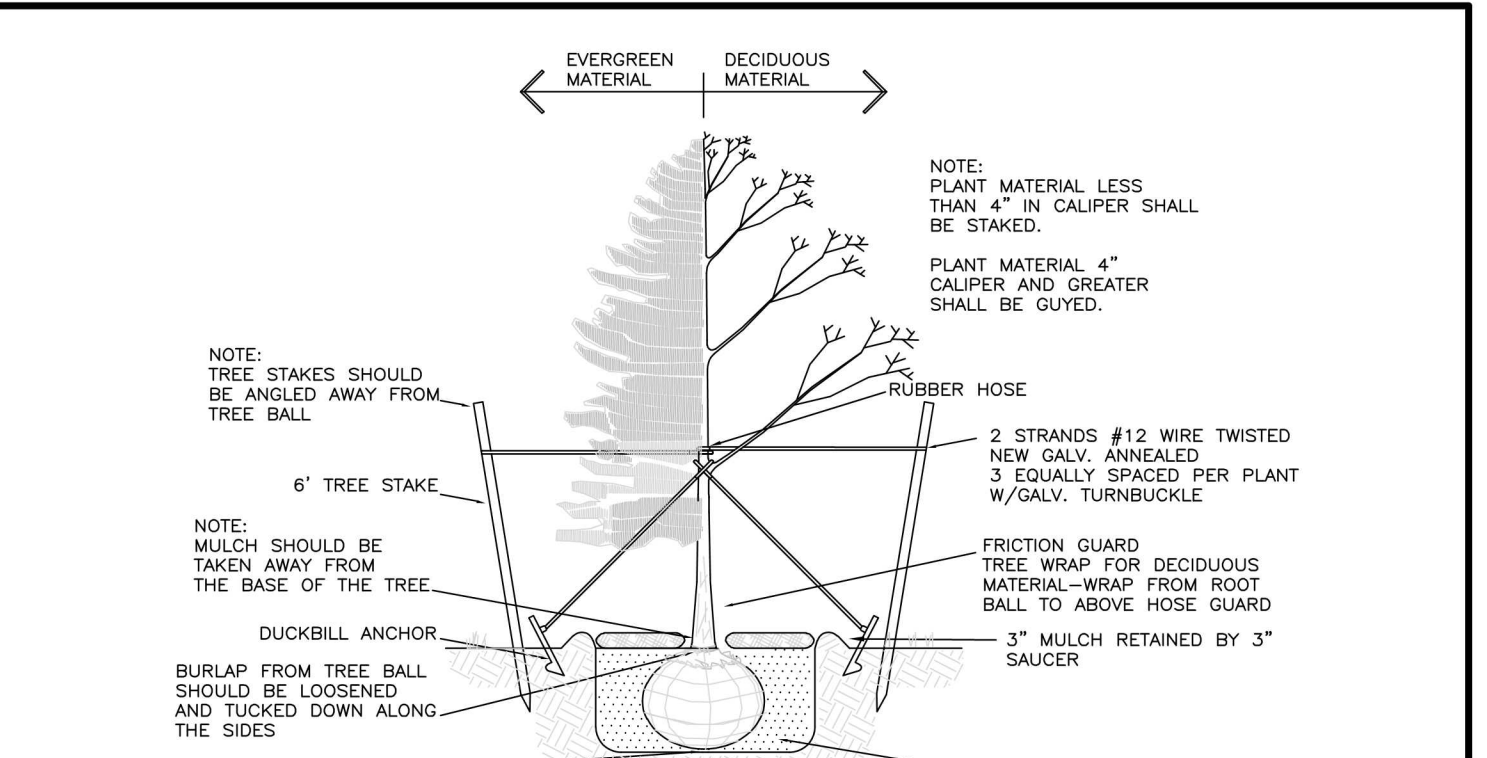

TREE PLANTING DETAIL
N.T.S.

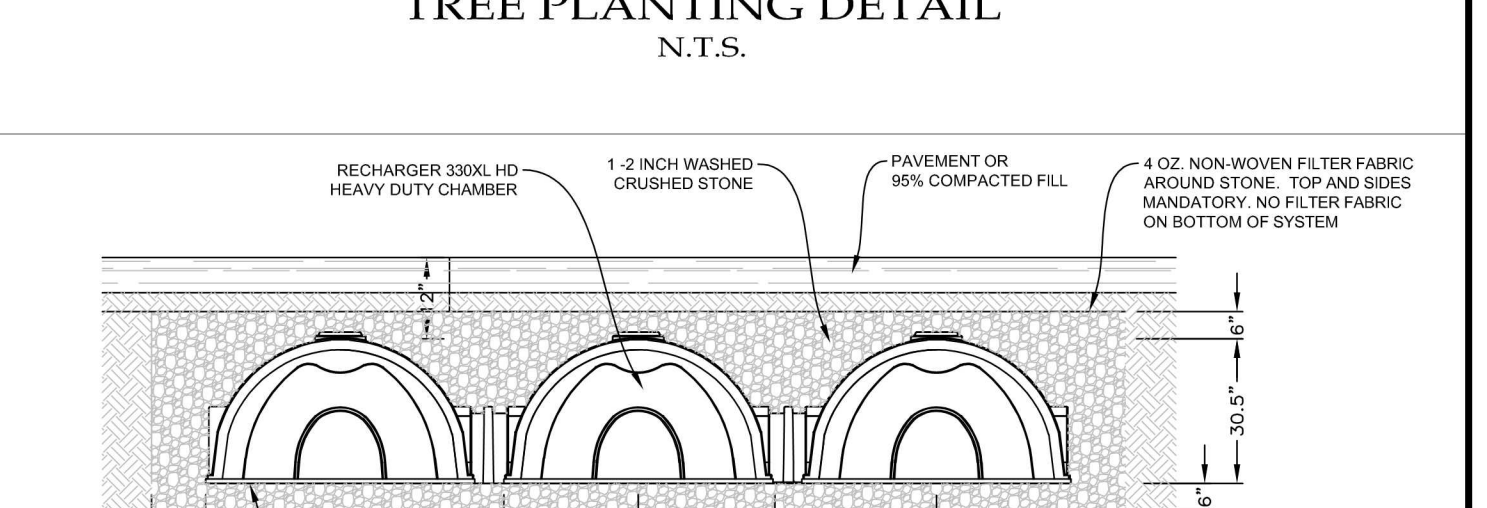

STORMWATER CHAMBER CROSS SECTION
N.T.S.

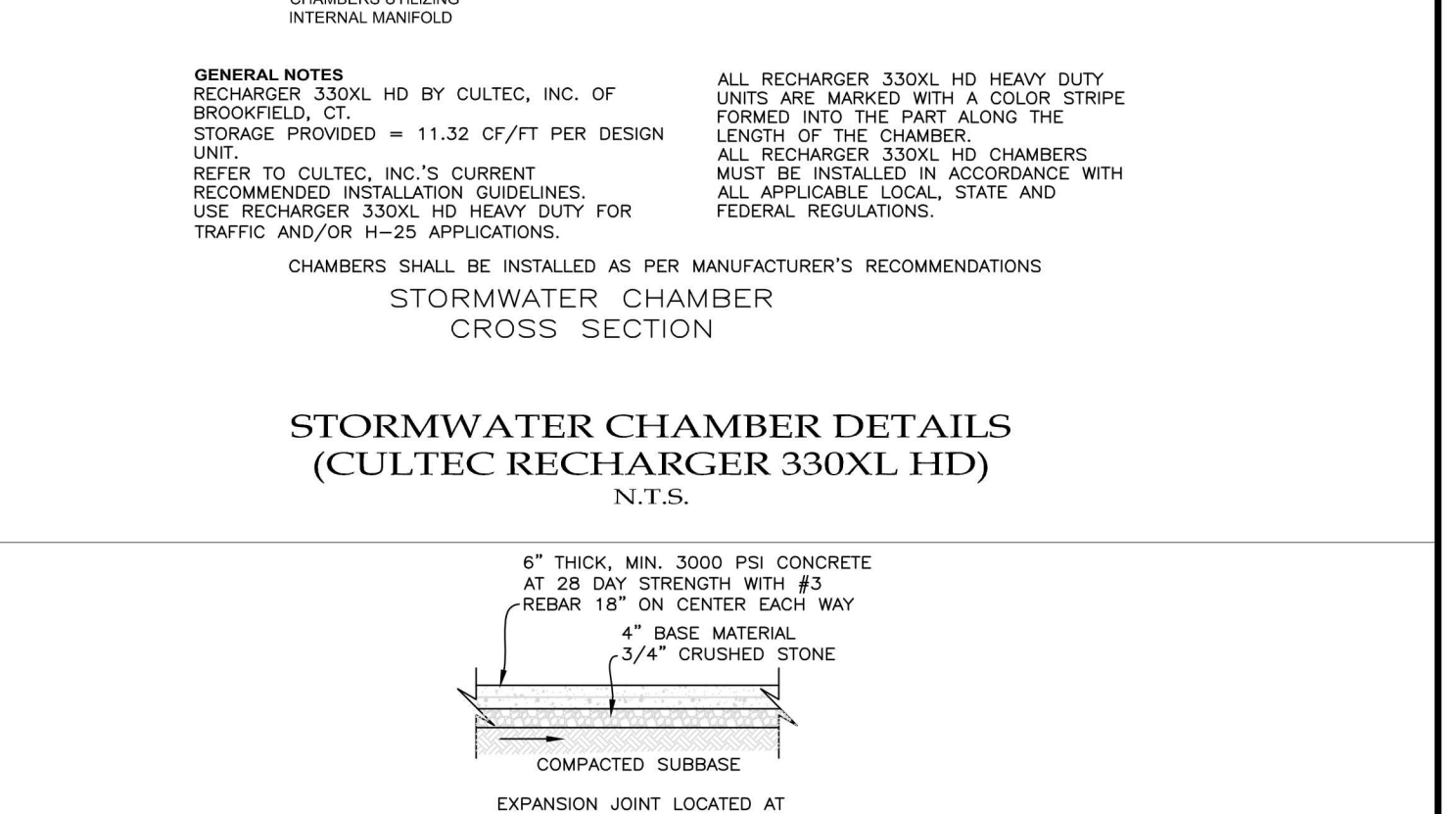

STORMWATER CHAMBER DETAILS (CULTEC RECHARGER 330XL HD)
N.T.S.

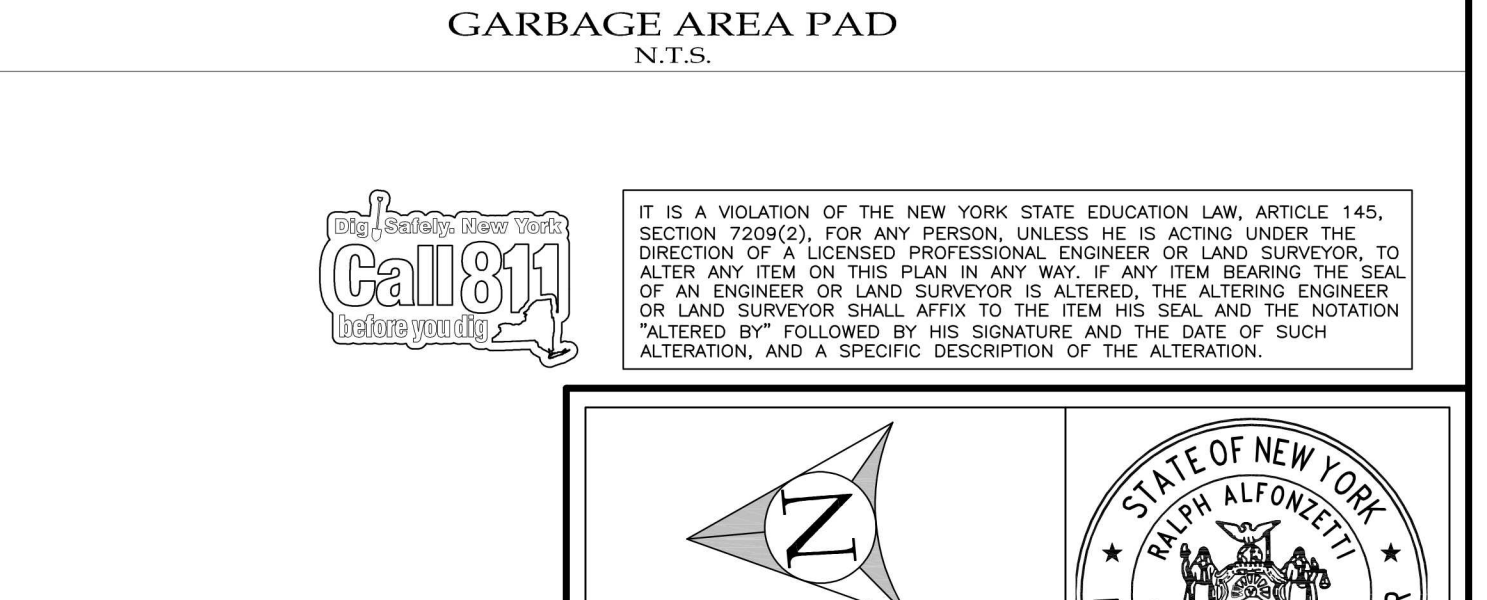

GARBAGE AREA PAD
N.T.S.

ALFONZETTI ENGINEERING, P.C.
14 SMITH AVE, MT. KISCO, N.Y. 10549
914-666-9800 INFO@ALFONZETTIENG.COM

STATE OF NEW YORK
RALPH ALFONZETTI
LICENSED PROFESSIONAL ENGINEER

SITE DATA

OWNER/APPLICANT: 2012 MARIA MARTINS IRREVOCABLE TRUST
SITE ADDRESS: 78 LAFAYETTE AVE, NORTH WHITE PLAINS, NY 10603
TAX MAP #: 12212-1-29
LOT AREA: 0.6115 AC
ZONING: IND-A
DATE: JUNE 8, 2023
REVISED: DECEMBER 12, 2022

SITE DETAILS
JUNE 13, 2022

78 LAFAYETTE AVENUE
TOWN OF NORTH CASTLE,
WESTCHESTER COUNTY, NEW YORK

FIRE DISTRICT: NORTH WHITE PLAINS FD
SCHOOL DISTRICT: VALHALLA
WATER DISTRICT: NORTH CASTLE WD#1
APPROVED BY TOWN OF NORTH CASTLE PLANNING BOARD RESOLUTION, DATED: _____
CHRISTOPHER CARRY, CHAIRMAN
TOWN OF NORTH CASTLE PLANNING BOARD
ENGINEERING PLANS REVIEWED FOR CONFORMANCE TO RESOLUTION: _____
JOSEPH M. CERMELE, P.E.
KELLARD SESSIONS CONSULTING
CONSULTING TOWN ENGINEERS

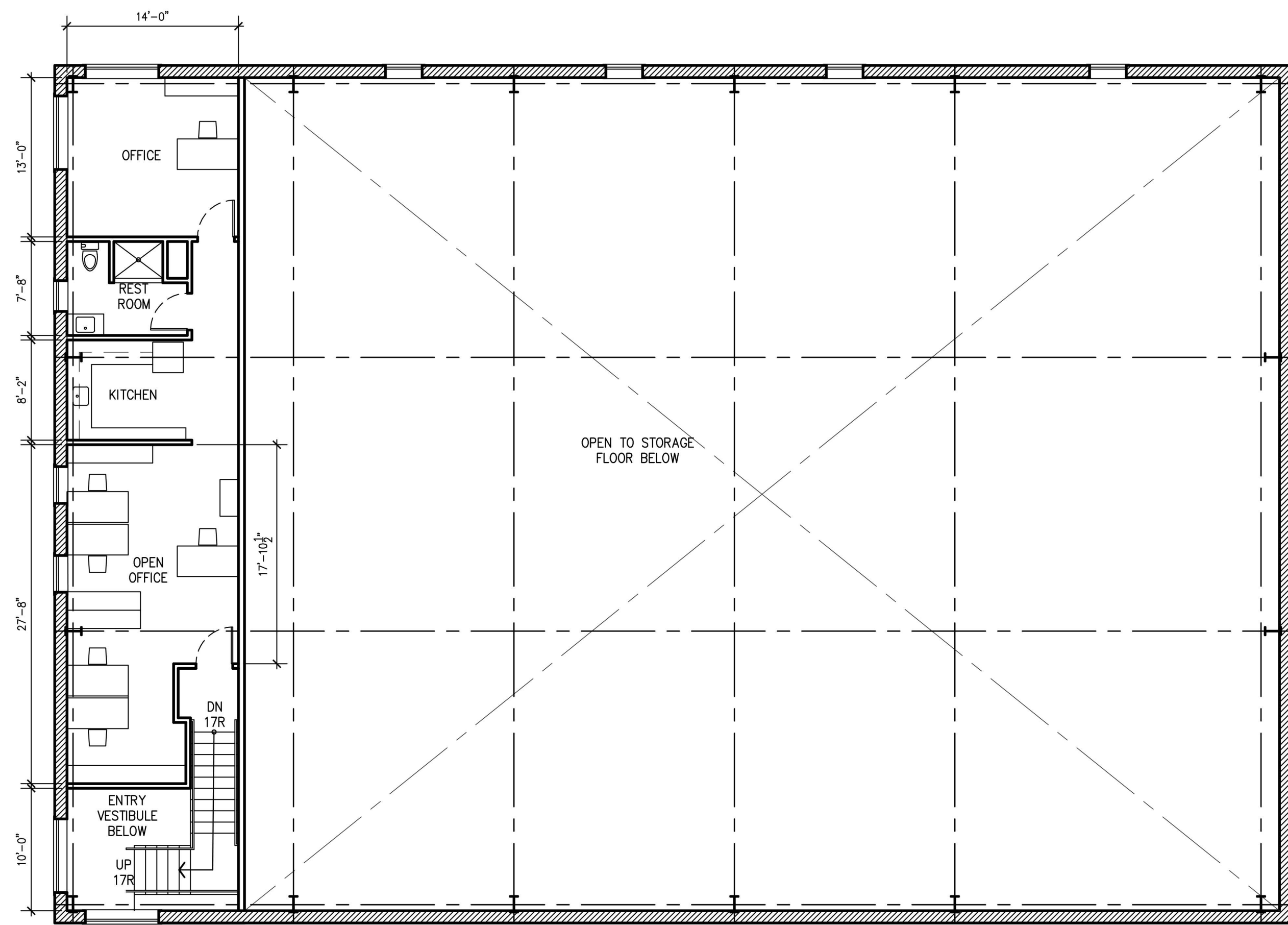
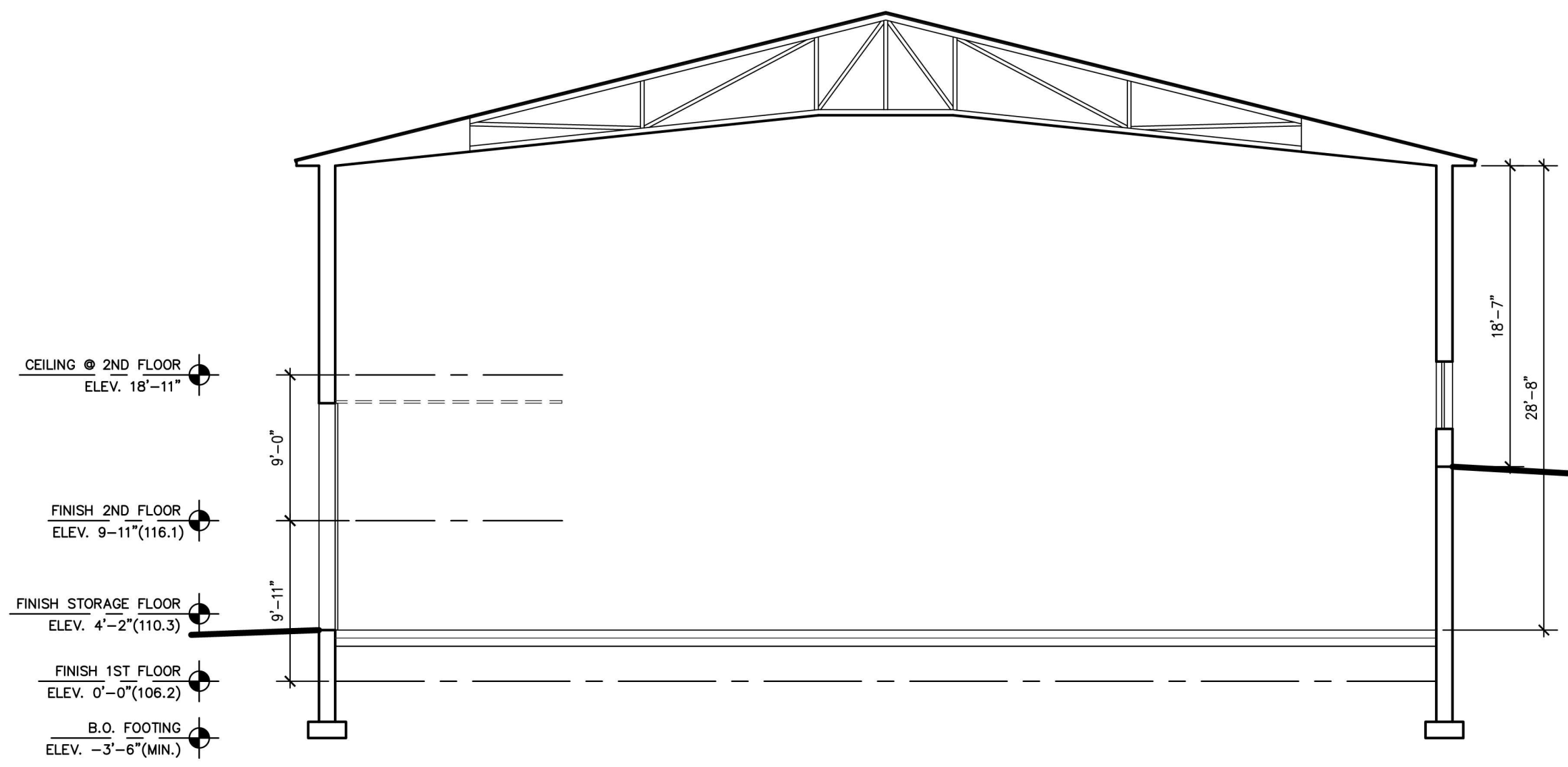

2 UPPER FLOOR PLAN
1/8" = 1'-0"

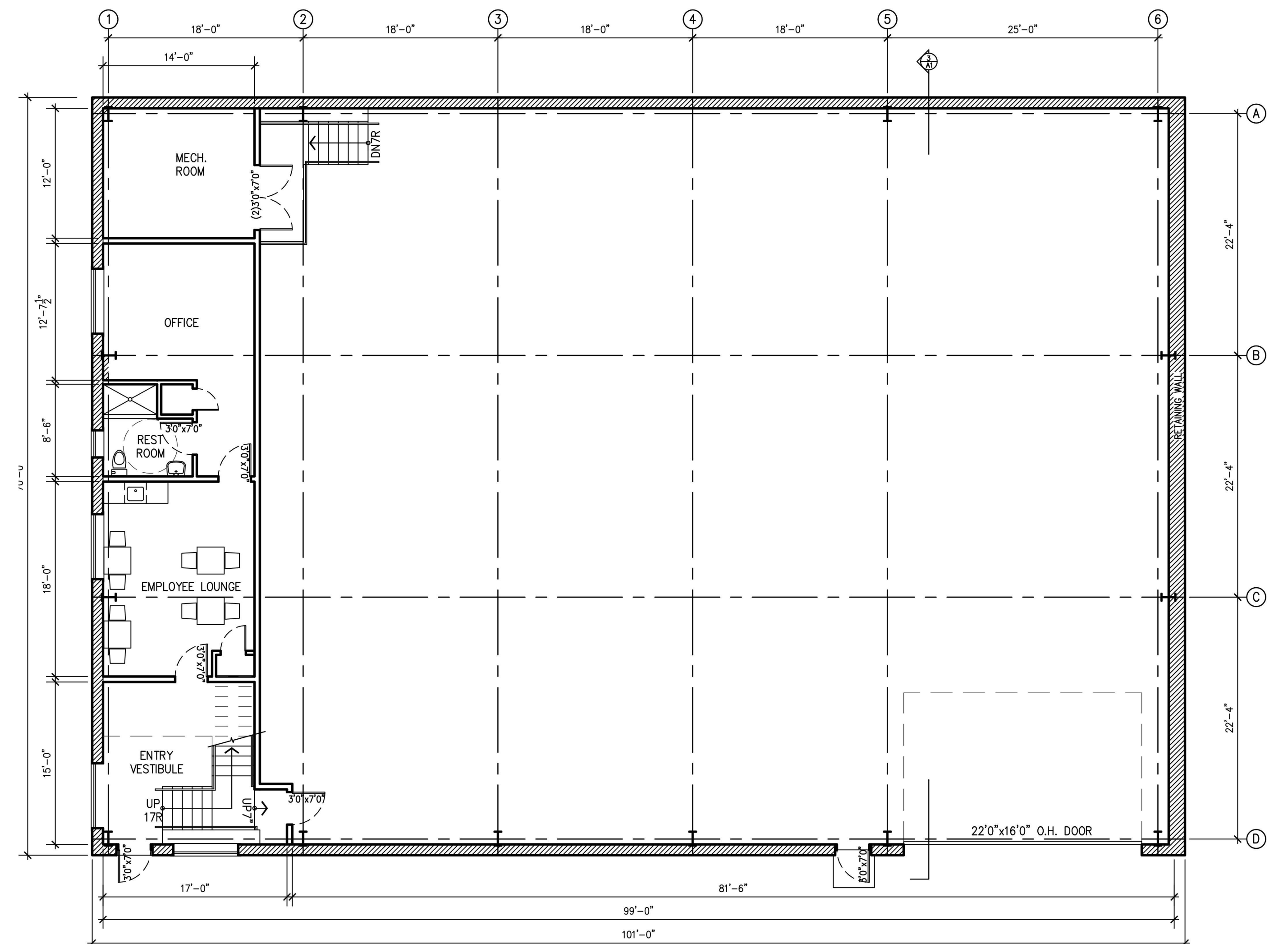

1 MAIN FLOOR PLAN
1/8" = 1'-0"

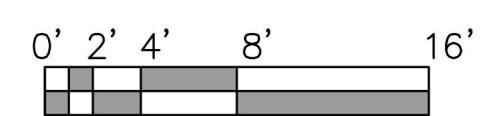

NOTE:
ALL IDEAS, DESIGNS, ARRANGEMENTS AND PLANS INDICATED OR REPRESENTED BY THIS DRAWING ARE OWNED BY AND ARE THE PROPERTY OF VKS ARCHITECTS, AND WERE CREATED, EVALUATED AND DEVELOPED FOR USE ON, AND IN CONNECTION WITH, THE SPECIFIED PROJECT. NONE OF SUCH IDEAS, DESIGNS, ARRANGEMENTS OR PLANS SHALL BE USED BY OR DISCLOSED TO ANY PURPOSE WHATSOEVER WITHOUT THE WRITTEN PERMISSION OF VKS ARCHITECTS.

WRITTEN DIMENSIONS ON THIS DRAWING SHALL HAVE PRECEDENCE OVER SCALED DIMENSIONS. CONTRACTOR SHALL VERIFY AND BE RESPONSIBLE FOR ALL DIMENSIONS AND CONDITIONS ON THE JOB AND THIS OFFICE MUST BE NOTIFIED OF ANY VARIATIONS FROM DIMENSIONS AND CONDITIONS SHOWN BY THESE DRAWINGS. SHOP DETAILS MUST BE SUBMITTED TO THIS OFFICE FOR APPROVAL BEFORE PROCEEDING WITH FABRICATION.

LEGAL NOTICE:
ALTERATIONS BY ANY PERSON, IN ANY WAY, OF ANY ITEM CONTAINED ON THIS DOCUMENT UNLESS ACTING UNDER THE DIRECTION OF THE LICENSED ARCHITECT WHOSE PROFESSIONAL SEAL IS AFFIXED HERETO, IS A VIOLATION OF TITLE 16, SEC. 66.5 (a) OF NEW YORK STATE LAW.

vks
Architects
Post Office BOX 696
Katonah, NY 10536
914-232-9828
Fax: 914-232-9839
vks@vksa.com

TITLE
NEW OFFICE & STORAGE FACILITY
MTS INFRASTRUCTURE LLC
78 LAFAYETT AVENUE, WHITE PLAINS, NY, 10603
TAX MAP ID: 122.12-1-29
PROPOSED FLOOR PLANS & SCHEMATIC BUILDING SECTION

JOB NO.	2023-050	DWG. NO.	A1
DATE	06/09/2023		
SCALE	1/8" = 1'-0"		
DRAWN / CHECKED BY	VKSA		
JOB NAME	78 LAFAYETTE	OF	

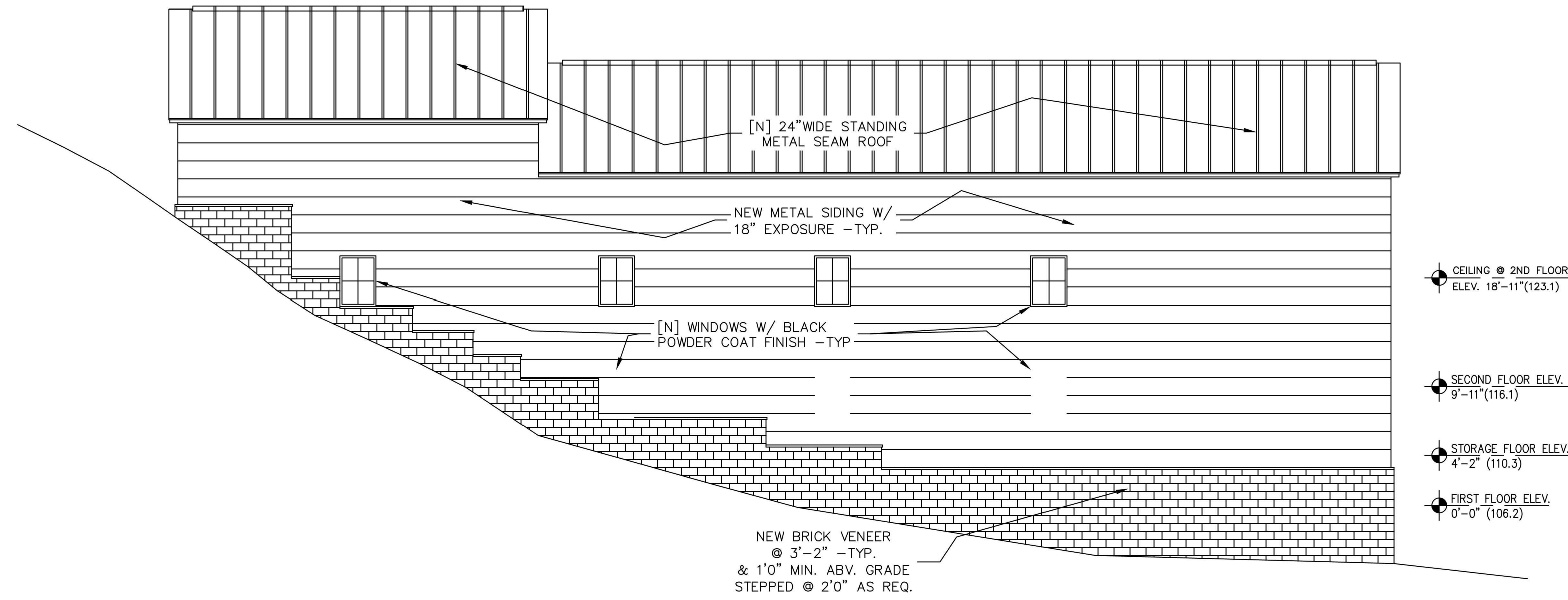

1 NORTH (LEFT SIDE) ELEVATION
1/8" = 1'-0"

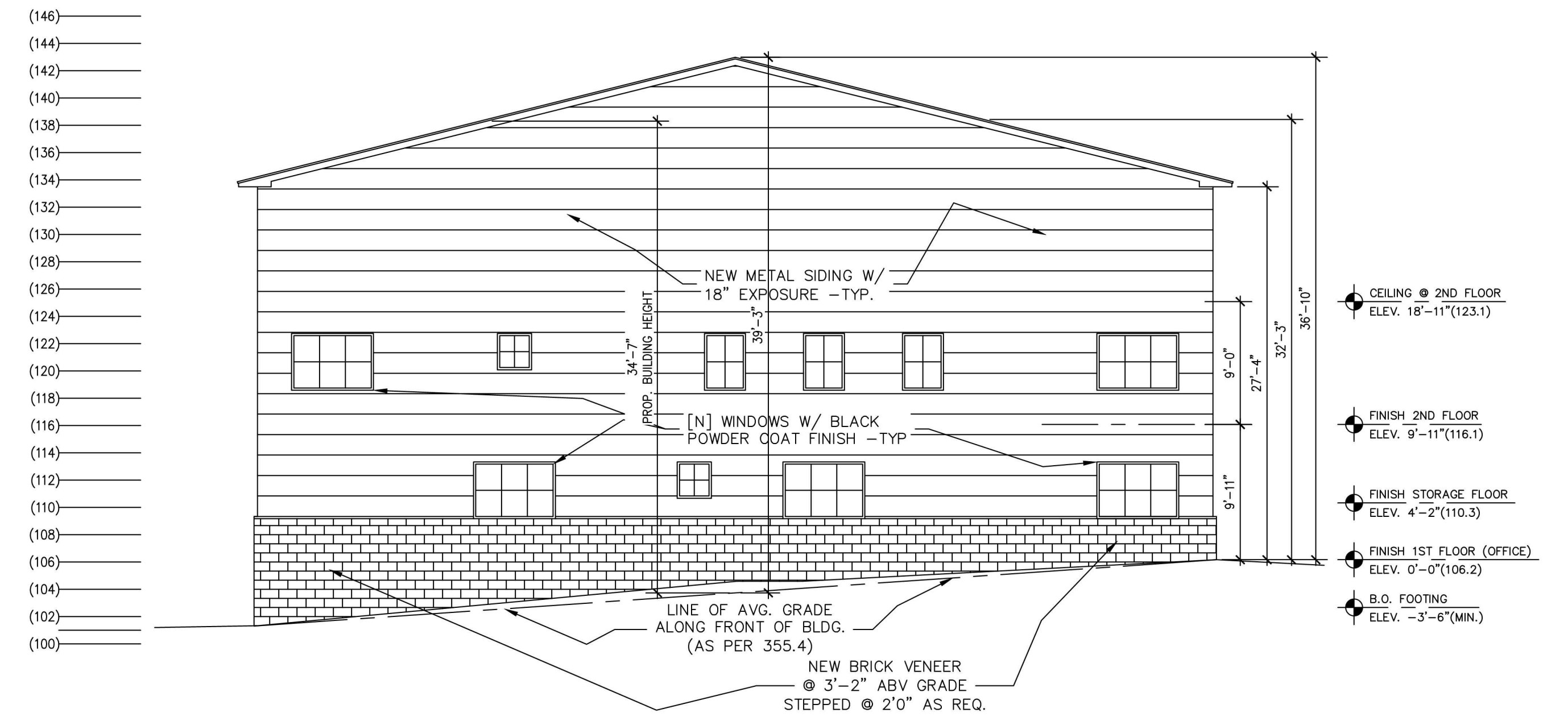

2 WEST (FRONT) ELEVATION
1/8" = 1'-0"

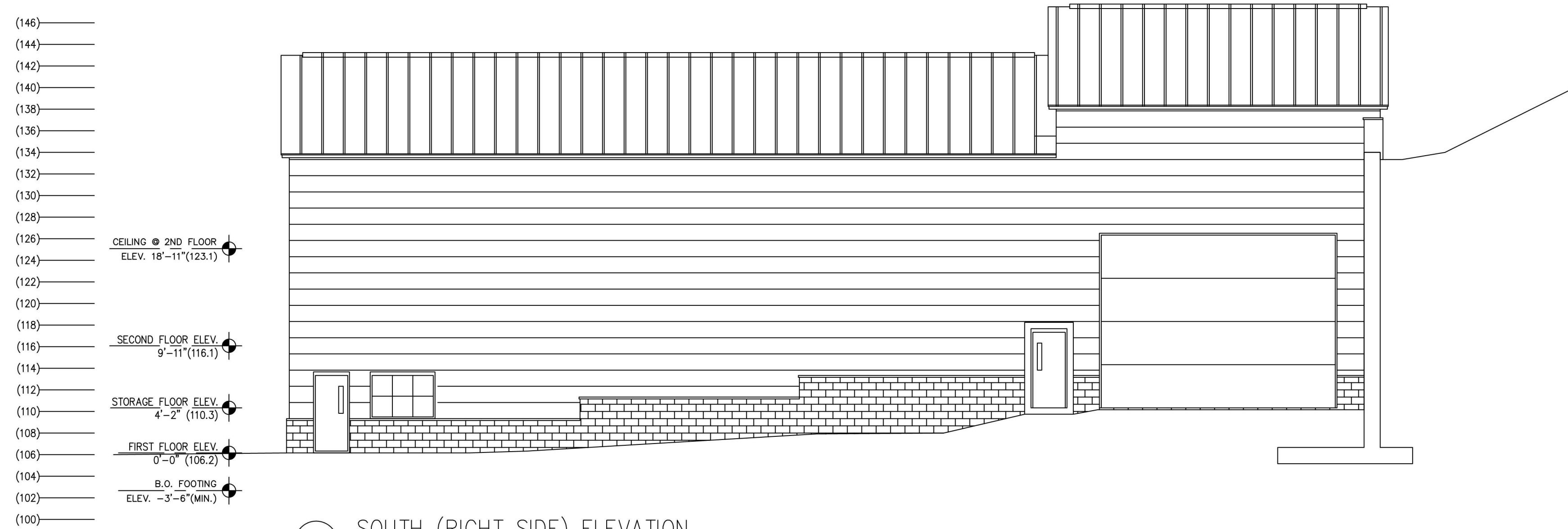

3 SOUTH (RIGHT SIDE) ELEVATION
1/8" = 1'-0"

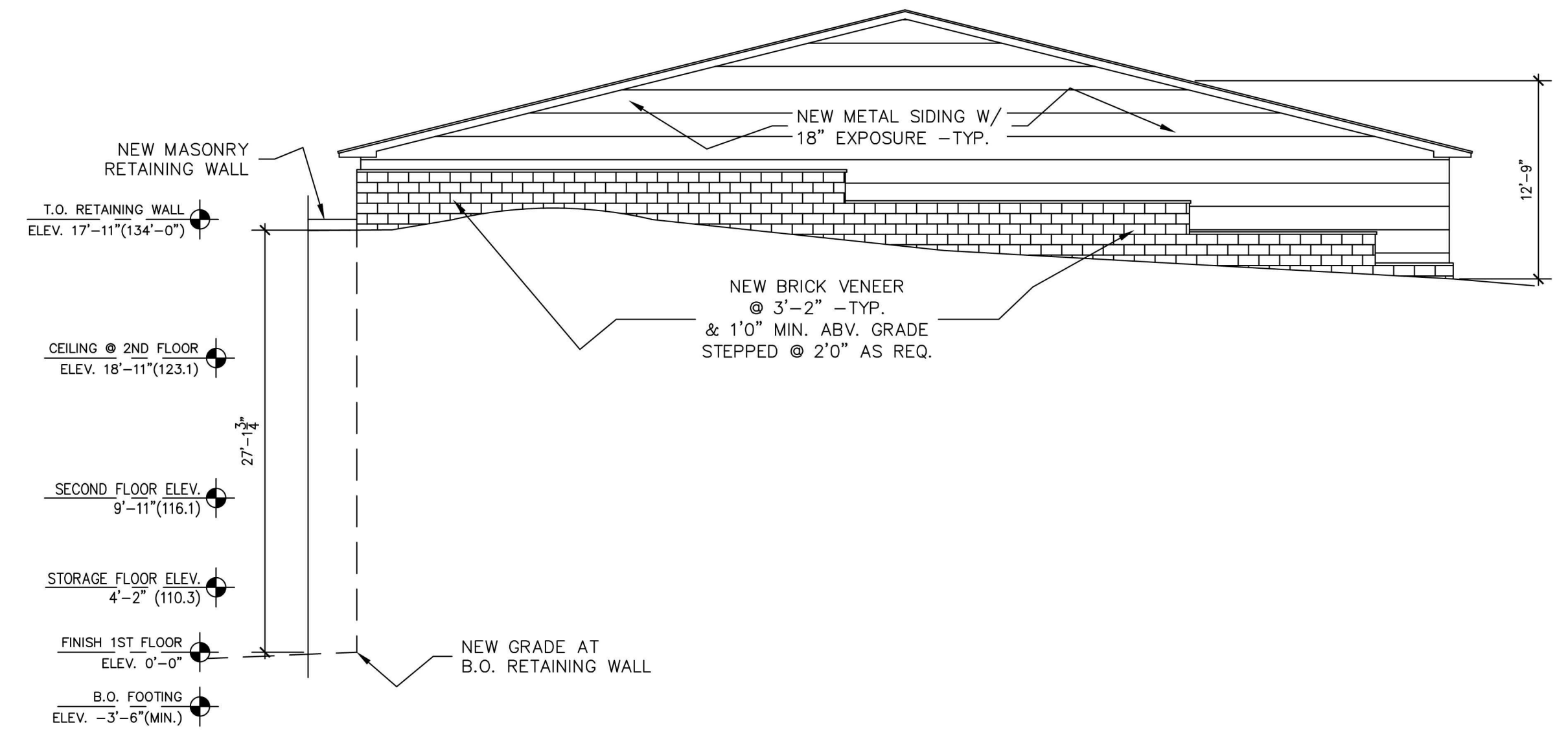

4 NORTH (REAR) ELEVATION
1/8" = 1'-0"

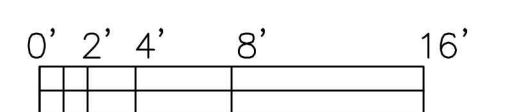

NOTE:
ALL IDEAS, DESIGNS, ARRANGEMENTS AND PLANS INDICATED OR REPRESENTED BY THIS DRAWING ARE OWNED BY AND ARE THE PROPERTY OF VKS ARCHITECTS, AND WERE CREATED, EVOLVED AND DEVELOPED FOR USE ON, AND IN CONNECTION WITH, THE SPECIFIED PROJECT. NONE OF SUCH IDEAS, DESIGNS, ARRANGEMENTS OR PLANS SHALL BE USED BY OR DISCLOSED TO ANY PURPOSE WHATSOEVER WITHOUT THE WRITTEN PERMISSION OF VKS ARCHITECTS.

WRITTEN DIMENSIONS ON THIS DRAWING SHALL HAVE PRECEDENCE OVER SCALED DIMENSIONS. CONTRACTOR SHALL VERIFY AND BE RESPONSIBLE FOR ALL DIMENSIONS AND CONDITIONS ON THE JOB AND THIS OFFICE MUST BE NOTIFIED OF ANY VARIATIONS FROM DIMENSIONS AND CONDITIONS SHOWN BY THESE DRAWINGS. SHOP DETAILS MUST BE SUBMITTED TO THIS OFFICE FOR APPROVAL BEFORE PROCEEDING WITH FABRICATION.

LEGAL NOTICE:
ALTERATIONS BY ANY PERSON, IN ANY WAY, OF ANY ITEM CONTAINED ON THIS DOCUMENT, UNLESS ACTING UNDER THE DIRECTION OF THE LICENSED ARCHITECT WHOSE PROFESSIONAL SEAL IS AFFIXED HERETO, IS A VIOLATION OF TITLE 16, SECT. 665 (6) OF NEW YORK STATE LAW.

vks
Architects
Post Office BOX 696
Katonah, NY 10536
914-232-9828
Fax: 914-232-9839
vks@vksa.com

TITLE
NEW OFFICE & STORAGE FACILITY
MTS INFRASTRUCTURE LLC
78 LAFAYETTE AVENUE, WHITE PLAINS, NY, 10603
TAX MAP ID: 122.12-1-29
PROPOSED BUILDING ELEVATIONS

JOB NO.	2023-050	DWG. NO.	
DATE	06/09/2023		
SCALE	1/8" = 1'-0"		
DRAWN / CHECKED BY	VKSA		
JOB NAME	78 LAFAYETTE		

A2