



**HOCHERMAN  
TORTORELLA  
& WEKSTEIN LLP**

Attorneys at Law  
Geraldine N. Tortorella<sup>(NY, CT)</sup>  
Adam L. Wekstein<sup>(NY)</sup>  
Noelle C. Wolfson<sup>(NY, CT)</sup>

---

Henry M. Hocherman, Retired

January 29, 2024

*Via Electronic Mail ([jhuerta@northcastleny.com](mailto:jhuerta@northcastleny.com))  
and First Class Mail*

Hon. Christopher Carthy, Chairman  
and Members of the Planning Board  
Town Hall Annex  
17 Bedford Road  
Armonk, New York 10504

*Re: Supplemental Submission for:*  
*(i) Application of Round Hill Land Corp. for Site Plan Approval and Wetland Permit for Pool  
Renovation, Access Path & Tee*  
*Property: 94 Round Hill Road, Town of North Castle*  
*Tax Identification No.: Section 109.01, Block 01, Lot 24; and*  
*(ii) Application of Michael Lehrer for Site Plan Approval and Wetland Permit to Reconstruct and  
Expand Golf Green, Tees, Access Path & Storage Shed*  
*Property: 92 Round Hill Road, Town of North Castle*  
*Tax Identification No.: Section 109.01, Block 01, Lot 25*

Dear Chairman Carthy and Members of the Planning Board:

This firm represents Round Hill Land Corp. (the “Corporation”), owner of the property at 94 Round Hill Road (the “94 Property”) and Michael Lehrer (“Lehrer”), owner of the property at 92 Round Hill Road (the “92 Property”). On September 11, 2023, we filed with the Board applications for Wetlands Permits for both the 94 Property and the 92 Property and were advised that site plan approval would also be required for the improvements at issue in the wetlands permit applications. We make this submission to supplement our September 11<sup>th</sup> submission.

Enclosed for filing are electronic copies of site plan applications for the 94 Property and the 92 Property, signed by the owners thereof. We are submitting with a hard copy of this letter four checks for the site plan application fees and escrow deposits for each parcel.

The scope of work, plans and wetland analysis previously submitted to the Board have not changed. Therefore, please combine the enclosed materials with those submitted on September 11, 2023. Should you need another copy of the prior submission or for us to “package” the materials differently, please let me know.

Hon. Christopher Carthy, Chairman  
and Members of the Planning Board  
January 29, 2024  
Page 2

We would appreciate it if the Board would schedule this matter for its February 26, 2024 meeting to discuss our clients' goals and objectives and their proposed means of achieving them. We look forward to working with the Board to resolve the Wetland Permit and Site Plan applications.

Respectfully yours,

Hocherman Tortorella & Wekstein, LLP

By:   
Geraldine N. Tortorella

GNT:hc

Enclosures

cc: *(via electronic mail with enclosures)*

Robert Melillo, Building Inspector

Adam Kaufman, AICP

Roland Baroni, Jr., Esq.

Tim Allen, P.E.

Mary Jaehnig

Round Hill Land Corp.

Mr. Michael Lehrer

*(via electronic mail without enclosures)*

Patrick J. Bliss, Esq



**TOWN OF NORTH CASTLE**  
**WESTCHESTER COUNTY**  
17 Bedford Road  
Armonk, New York 10504-1898

**PLANNING DEPARTMENT**  
Adam R. Kaufman, AICP  
Director of Planning

Telephone: (914) 273-3542  
Fax: (914) 273-3554  
[www.northcastleny.com](http://www.northcastleny.com)

## Application for Site Development Plan Approval

### Application Name

Round Hill Land Corp. - Pool Renovation, Access Path and Golf Tee

---

94 Round Hill Road



TOWN OF NORTH CASTLE  
WESTCHESTER COUNTY  
17 Bedford Road  
Armonk, New York 10504-1898

PLANNING DEPARTMENT  
Adam R. Kaufman, AICP  
Director of Planning

Telephone: (914) 273-3542  
Fax: (914) 273-3554  
[www.northcastleny.com](http://www.northcastleny.com)

### Important General Information

- Prior to submitting an application, the "Notice to Applicants" should be reviewed.
- To appear before the Planning Board, all required application materials shall be submitted not later than **12:00 P.M., Monday, fourteen (14) days** prior to the date of the Planning Board meeting at which the application is scheduled to be heard or as otherwise noted by the Planning Board Secretary. Continuing Business can be submitted 12 days prior to the Next Planning Board meeting by the close of business. Except where noted.  
If all required application materials, including the pertinent application fee and escrow monies are not submitted by that deadline, the application shall be automatically removed from the agenda.  
At the discretion of the Planning Board Chairman, the application may be rescheduled, if appropriate, for the next available Planning Board meeting or the application may be removed from future agendas altogether. Without prior authorization from the Planning Board, application submissions shall not be accepted at Planning Board meetings.
- At the time of submission, all required application materials shall be submitted. **Piecemeal** submissions **shall not** be accepted. Substitution of previously submitted materials shall not be permitted.
- All submissions shall be dated, with revision dates identified on new submissions.
- All submissions shall be accompanied by a cover letter describing the project and/or any changes as compared to previous submissions.
- To be considered complete for Planning Board hearing purposes, an application package shall contain the information identified in Parts IV and V of this application form.



**TOWN OF NORTH CASTLE  
WESTCHESTER COUNTY  
17 Bedford Road  
Armonk, New York 10504-1898**

**PLANNING DEPARTMENT  
Adam R. Kaufman, AICP  
Director of Planning**

**Telephone: (914) 273-3542  
Fax: (914) 273-3554  
[www.northcastleny.com](http://www.northcastleny.com)**

**AT THE TIME OF SUBMISSION TO THE PLANNING DEPARTMENT  
PLEASE MAKE SURE THE FOLLOWING IS PROVIDED**

- ✓ SUBMISSION OF A SINGLE PDF FILE (PLANS, APPLICATION FORM, OTHER PAPERWORK) ON A DISK, THUMBDRIVE OR EMAIL
  
- ✓ COVER LETTER DESCRIBING THE PROJECT OR CHANGES TO THE PROJECT
  
- ✓ ALL PLANS ARE SIGNED AND SEALED BY A LICENSED NYS PROFESSIONAL



**TOWN OF NORTH CASTLE**  
**WESTCHESTER COUNTY**  
17 Bedford Road  
Armonk, New York 10504-1898

**PLANNING DEPARTMENT**  
Adam R. Kaufman, AICP  
Director of Planning

Telephone: (914) 273-3542  
Fax: (914) 273-3554  
[www.northcastleny.com](http://www.northcastleny.com)

## **NOTICE TO APPLICANTS**

In the Town of North Castle, the Planning Board is responsible for the review and approval of all applications concerning site plans, subdivisions and lot line changes; some applications concerning special use permits, wetlands permits and tree removal permits; and the environmental review of those applications over which it has jurisdiction. The Planning Board may also have an advisory role in connection with some applications before the Town Board, such as those involving other categories of special use permits and zoning amendments.

The Planning Board is composed of five volunteer members – all residents of North Castle – who are appointed by the Town Board for five-year terms. As part of the review of some applications, the Planning Board is assisted on an as-needed basis by other lay boards of the Town, such as the Conservation Board (CB), the Zoning Board of Appeals (ZBA), the Open Space Committee and the Architectural Review Board (ARB). As part of the review of most applications, the Planning Board is also assisted by the Director of Planning, the Town Engineer, the Town Attorney and other special consultants when required.

### **FEES:**

If you submit an application for Planning Board review, you will be required to reimburse the Town for the cost of professional review services, including legal and engineering services, incurred in connection with the review of your application. The charges for professional planning review services have been \$120/hour. If other types of professional consultant review services are required, those charges will be in accord with fees usually charged for such services and pursuant to a contractual agreement between the Town and such professional.

At the time of submission of an application, the Planning Board will require the establishment of an escrow account from which withdrawals shall be made to reimburse the Town for the cost of consultant fees and professional staff services.

### **ESCROW ACCOUNT:**

Escrow Accounts are established for each application. Monies will be deducted from the account for professional review services rendered. Monthly escrow disbursement summaries will be mailed for your reference regarding your project. When the balance in such escrow account is reduced to one-third (1/3) of its initial amount, a letter will be mailed to the applicant and the applicant shall deposit additional funds into such account to restore its balance to the amount of the initial deposit. Additional information on these requirements is provided in the North Castle Town Code (see Sections 355-79B and 275-36.C).



**TOWN OF NORTH CASTLE**  
**WESTCHESTER COUNTY**  
17 Bedford Road  
Armonk, New York 10504-1898

**PLANNING DEPARTMENT**  
Adam R. Kaufman, AICP  
Director of Planning

Telephone: (914) 273-3542  
Fax: (914) 273-3554  
[www.northcastleny.com](http://www.northcastleny.com)

**PROCEDURE:**

Prior to submitting an application to the Planning Board for review and approval, prospective applicants should schedule an appointment with the Planning Board Secretary at (914) 273-3542 for a consultation with the Town Planner and the Town Engineer. When the appointment is made, a verbal description of the proposal should be provided to the Planning Board Secretary. The Town of North Castle is providing the services of the Director of Planning and the Town Engineer for *initial* consultation at no cost to the applicant so that it is possible to conduct the application review as efficiently as possible for the benefit of the applicant as well as the Planning Board.

After meeting with the Town Planner and Town Engineer, prospective applicants should prepare one complete set of application documents and plans. This set will be reviewed for completeness by the Town Planner. If determined to be incomplete, the Planning Department will submit a checklist indicating which items have not been adequately addressed. If determined to be complete, the checklist will be initialed and the Applicant should submit the remainder of the required application packages.

Once the checklist has been initialed and all application packages have been submitted, the Planning Board Secretary will schedule the application for the first available opening on the Planning Board's meeting agenda. However, if the required application material packages, including the pertinent application fee are not received at the Planning Board office by 12:00 PM, Monday, 14 days prior to the date of the Planning Board meeting at which you are scheduled to appear (or otherwise scheduled by the Planning Board Secretary), your application will be automatically removed from the agenda. At the discretion of the Planning Board Chairman, your application may be rescheduled, if appropriate, for the next available Planning Board meeting or the application may be removed from future agendas altogether. Additional requirements pertinent to each type of application are provided on the individual application forms, which you should carefully review prior to submitting your application.

When an application is deemed complete and submitted for review, it will be forwarded to the Planning Board Members and its professional advisors in advance of the meeting to allow adequate time for review, preparation of written reports and site inspections as necessary. Your application may also be forwarded to other boards and staff of the Town as well as to agencies outside of the Town, if required. Compliance with State Environmental Quality Review (SEQR) procedures is also required as part of the processing of all applications.

At your first appearance before the Planning Board, the Applicant will describe the project and the Planning Board will discuss any preliminary issues. The Planning Board discussion may be continued at future meetings, or if the Planning Board review has progressed sufficiently, the Application may be scheduled for a public hearing (if one is required) The public hearing may occur at a single Planning Board meeting, or it may be adjourned and continued at another Planning Board meeting. Because the nature and complexity of each application varies



**TOWN OF NORTH CASTLE  
WESTCHESTER COUNTY  
17 Bedford Road  
Armonk, New York 10504-1898**

**PLANNING DEPARTMENT  
Adam R. Kaufman, AICP  
Director of Planning**

**Telephone: (914) 273-3542  
Fax: (914) 273-3554  
[www.northcastleny.com](http://www.northcastleny.com)**

considerably, it is not possible to predict in advance the length of time needed to secure Planning Board approval. There are certain steps that you can take, however, to expedite the review process. These include, but are not limited to, the following:

- Be thoroughly familiar with the requirements pertinent to your application. Carefully review relevant provisions of the North Castle Town Code and the application form for your particular type of application. Be sure to check on what other types of approvals may be required in addition to that of the Planning Board. Approvals by other Town boards or departments as well as agencies outside of the Town may be required before you will be allowed to proceed with your project.
- Make sure that your application materials are accurately prepared and contain all required information. The information that we initially request is required, so make sure that your submission is complete. If supplementary information is requested as the review process continues, make sure that it is submitted in a timely fashion so the Planning Board can continue to move your application along.
- Follow up to make sure that your application materials are being submitted on time, or deliver them to the Planning office yourself.
- Attend the Planning Board meeting at which your application will be discussed and be on time for the meeting. If you cannot appear personally, make sure that your representative will be there and is thoroughly familiar with your application.

If the Application is approved by the Planning Board, a resolution of approval will be adopted by the Planning Board. It is the Applicant's responsibility to address any and all conditions of approval. Permits from the Building Department cannot be issued until all conditions have been addressed and the plans have been signed by the Planning Board Chair and the Town Engineer.

**ON LINE AGENDAS & PLANNING DEPARTMENT MEMORANDA CAN BE  
REVIEWED AT**

**[WWW.NORTHCASTLENY.COM](http://WWW.NORTHCASTLENY.COM)**





TOWN OF NORTH CASTLE  
WESTCHESTER COUNTY  
17 Bedford Road  
Armonk, New York 10504-1898

PLANNING DEPARTMENT  
Adam R. Kaufman, AICP  
Director of Planning

Telephone: (914) 273-3542  
Fax: (914) 273-3554  
[www.northcastleny.com](http://www.northcastleny.com)

### INFORMATION REGARDING PUBLIC HEARINGS

1. The North Castle Assessor's Office shall prepare a list of neighbors to be notified for the neighbor notifications and public hearings - **A minimum of one week's notice is required**. The fee is \$50.00 which includes the list of neighbors and two sets of labels for mailing. The Assessor's Office may be reached Monday – Friday from 8:30 a.m.– 4:30 p.m. at 273-3324. You may also e-mail your request to [assessor@northcastleny.com](mailto:assessor@northcastleny.com)

When requesting your list please reference the list of application types below so that you can tell the Assessor's office how many feet on all sides of the property to create the list for.

**Subdivisions** - All lots zoned R-10, R-5 and R-2F shall notice all neighbors within 200 feet from all sides of their property. All other zoning districts shall notice neighbors within 500 feet from all sides of their property. Public hearing notice must be published in the newspaper.

**Special Use Permit for Structures over 800 sq ft. & Accessory Apartment** - All Zoning Districts shall notice all neighbors within 250 feet from all sides of their property. Public hearing notice must be published in the newspaper.

**Site Plan, Non Residential** - All Zoning Districts shall notice all neighbors within 250 feet from all sides of their property. Public hearing notice must be published in the newspaper.

**Site Plan, Residential/ Neighbor Notification** – All zoning districts R-3/4A or smaller shall notice all neighbors within 250' from all sides of their property. All zoning districts zoned R-1A or larger shall notice all neighbors within 500' from all sides of the property. No public hearing required, no publication in the newspaper required.

**Wetlands Permit** - All Zoning Districts shall notice all abutting property owners. Public hearing notice must be published in the newspaper.

2. The Director of Planning will prepare a Public Notice. The applicant and or professional will review, sign, date and return to the Planning Department Secretary. If there are any changes necessary, please edit and return for corrections. The corrections will be made and emailed back to the applicant who will forward it to the Journal Newspaper, when applicable.

**If notification to the newspaper is not required, please continue to #3.**



**TOWN OF NORTH CASTLE**  
**WESTCHESTER COUNTY**  
**17 Bedford Road**  
**Armonk, New York 10504-1898**

**PLANNING DEPARTMENT**  
**Adam R. Kaufman, AICP**  
**Director of Planning**

**Telephone: (914) 273-3542**  
**Fax: (914) 273-3554**  
[www.northcastleny.com](http://www.northcastleny.com)

You may email your public notice to [legals@lohud.com](mailto:legals@lohud.com). Please request an affidavit of publication which must be submitted to the Planning Board secretary prior to the public hearing. The Journal News requires three days prior notice before 12 noon, not counting weekends and holidays, for ad placement. Make sure the notice placement of the ad in the Greater Westchester Area. This notice cannot be published any sooner than 20 days prior to the meeting and must be published no less than 10 days prior to the meeting.

If you have any questions regarding your publication you may call 888-516-9220:  
Email Address: [legals@lohud.com](mailto:legals@lohud.com)

It is suggested that you purchase the newspaper for your records the day the notice is published.

3. Send out the Public Hearing Notice/ Neighbor Notification by First Class Mail. Notice shall be mailed by the applicant in official envelopes provided by the North Castle Planning Department; the list of noticed neighbors will be prepared by the Assessor's Office. This must be sent out no less than 10 days prior to the meeting and no more than 20 days prior to the meeting date. A Certificate of Mailing (PS Form 3817 or 3877) shall be filled out and post marked by the Post Office on the day of mailing. Neighbor Notifications – no publication in the newspaper required.
4. The Friday before the meeting or no later than 12:00 p.m. the day of the meeting the following **must** be submitted.
  - List of Neighbors prepared by the Assessor's Office
  - Certificate of Mailing – PS form 3817 or 3877 post marked by the US Post Office
  - Affidavit of publication from the Newspaper (only if published in the newspaper)



Name and Address of Sender

Check type of mail or service

Adult Signature Required       Priority Mail Express

Adult Signature Restricted Delivery       Registered Mail

Certified Mail       Return Receipt for Merchandise

Certified Mail Restricted Delivery       Signature Confirmation

Collect on Delivery (COD)       Signature Confirmation Restricted Delivery

Insured Mail

Priority Mail

**Affix Stamp Here**  
*(if issued as an international certificate of mailing or for additional copies of this receipt).*  
**Postmark with Date of Receipt.**

USPS Tracking/Article Number	Addressee (Name, Street, City, State, & ZIP Code™)	Postage	(Extra Service) Fee	Handling Charge	Actual Value if Registered	Insured Value	Due Sender if COD	ASR Fee	ASRD Fee	RD Fee	RR Fee	SC Fee	SCRD Fee	SH Fee
1.														
2.														
3.														
4.														
5.														
6.														
7.														
8.														
Total Number of Pieces Listed by Sender	Total Number of Pieces Received at Post Office	Postmaster, Per (Name of receiving employee)												

Handling Charge - if Registered and over \$50,000 in value

Adult Signature Required

Adult Signature Restricted Delivery

Restricted Delivery

Return Receipt

Signature Confirmation

Signature Confirmation Restricted Delivery

Special Handling



**TOWN OF NORTH CASTLE**  
**WESTCHESTER COUNTY**  
17 Bedford Road  
Armonk, New York 10504-1898

**PLANNING DEPARTMENT**  
Adam R. Kaufman, AICP  
Director of Planning

Telephone: (914) 273-3542  
Fax: (914) 273-3554  
[www.northcastleny.com](http://www.northcastleny.com)

**APPLICATIONS REQUIRING PLANNING BOARD APPROVAL**  
**SCHEDULE OF APPLICATION FEES**

<b><u>Type of Application</u></b>	<b><u>Application Fee</u></b>
Site Development Plan	\$200.00
Each proposed Parking Space	\$10
Special Use Permit (each)	\$200 (each)
Preliminary Subdivision Plat	\$300 1 <sup>st</sup> Lot \$200 (each additional lot)
Final Subdivision Plat	\$250 1 <sup>st</sup> Lot \$100 (each additional lot)
Tree Removal Permit	\$75
Wetlands Permit	\$50 (each)
Short Environmental Assessment Form	\$50
Long Environmental Assessment Form	\$100
Recreation Fee	\$10,000 Each Additional Lot
Discussion Fee	\$200.00
Prior to submission of a sketch or preliminary subdivision Plat, an applicant or an applicant's representative wishes to discuss a subdivision proposal to the Planning Board, a discussion fee of \$200.00 shall be submitted for each informal appearance before the board.	

\*Any amendment to previously approved applications requires new application forms and Fes\*



TOWN OF NORTH CASTLE  
WESTCHESTER COUNTY  
17 Bedford Road  
Armonk, New York 10504-1898

PLANNING DEPARTMENT  
Adam R. Kaufman, AICP  
Director of Planning

Telephone: (914) 273-3542  
Fax: (914) 273-3554  
[www.northcastlenv.com](http://www.northcastlenv.com)

**PLANNING BOARD SCHEDULE OF ESCROW ACCOUNT DEPOSITS**

<u>Type of Application Deposit*</u>	<u>Amount of Initial Escrow Account</u>
Concept Study	\$500.00
Site Plan Waiver for Change of Use	\$500.00
Site Development Plan for:	
Multifamily Developments	\$3,000.00 plus \$100.00 per proposed dwelling unit
Commercial Developments	\$3,000.00 plus \$50.00 for each required parking space
1 or 2 Family Projects	\$2,000.00
Special Use Permit	\$2,000.00 plus \$50.00 for each required parking space
Subdivision:	
Lot Line Change resulting in no new lots	\$1,500.00
All Others	\$3,000.00 plus \$200.00 per proposed new lot in excess of two (2)
Preparation or Review of Environmental Impact Statement	\$15,000.00

\* If a proposed action involves multiple approvals, a single escrow account will be established. The total amount of the initial deposit shall be the sum of the individual amounts indicated. When the balance in such escrow account is reduced to one-third (1/3) of its initial amount, the applicant shall deposit additional funds into such account to restore its balance to the amount of the initial deposit.

Round Hill Land Corp.  
  
Applicant Signature

  
Date:

By: Michael Lehrer, President

**I. IDENTIFICATION OF PROPERTY OWNER, APPLICANT AND PROFESSIONAL REPRESENTATIVES**

Name of Property Owner: Round Hill Land Corp.  
Mailing Address: c/o Michael Lehrer, 92 Round Hill Road, Armonk, New York 10504  
Telephone: (914) 421-1800, Ext. 1 Fax: (914) 421-1856 e-mail g.tortorella@htwlegal.com

Name of Applicant (if different): N/A  
Address of Applicant: \_\_\_\_\_  
Telephone: \_\_\_\_\_ Fax: \_\_\_\_\_ e-mail \_\_\_\_\_  
Interest of Applicant, if other than Property Owner:  
\_\_\_\_\_

Is the Applicant (if different from the property owner) a Contract Vendee?  
Yes  No   
If yes, please submit affidavit stating such. If no, application cannot be reviewed by Planning Board

Name of Professional Preparing Site Plan:  
Bibbo Associates, LLP  
Address: 293 Route 100, Suite 203, Somers, New York 10589  
Telephone: (914) 277-5805 Fax: \_\_\_\_\_ e-mail tallen@bibboassociates.com

Name of Other Professional: Pfizer-Jahnig Environmental Consulting  
Address: 17 Fairview Avenue, Ridgefield, CT 06877  
Telephone: (203) 431-8113 Fax: \_\_\_\_\_ e-mail MaryJaehnigSoils@gmail.com

Name of Attorney (if any): Hocherman Tortorella & Wekstein, LLP (Geraldine N. Tortorella, Esq.)  
Address: One North Broadway, Suite 400, White Plains, New York 10601  
Telephone: (914) 980-9595 Fax: (914) 421-1856 e-mail g.tortorella@htwlegal.com

**Applicant Acknowledgement**

By making this application, the undersigned Applicant agrees to permit Town officials and their designated representatives to conduct on-site inspections in connection with the review of this application.

The Applicant also agrees to pay all expenses for the cost of professional review services required for this application.

It is further acknowledged by the Applicant that all bills for the professional review services shall be mailed to the Applicant, unless the Town is notified in writing by the Applicant at the time of initial submission of the application that such mailings should be sent to a designated representative instead.

Signature of Applicant: Michael Lehrer Pres.  
Round Hill Land Corp., By Michael Lehrer, President

Date: 1/7/24

Signature of Property Owner: Michael Lehrer Pres.  
Round Hill Land Corp., By Michael Lehrer, President

Date: 1/7/24

MUST HAVE BOTH SIGNATURES

**II. IDENTIFICATION OF SUBJECT PROPERTY**

Street Address: 94 Round Hill Road

Location (in relation to nearest intersecting street):

800 feet (north, south, east or west) of Gifford Lake Drive

Abutting Street(s): \_\_\_\_\_

Tax Map Designation (NEW):

Section 109.01 Block 1 Lot 24

Tax Map Designation (OLD): Section \_\_\_\_\_ Block \_\_\_\_\_ Lot \_\_\_\_\_

Zoning District: R-2A Total Land Area +/-4.32 ac.

Land Area in North Castle Only (if different) N/A

Fire District(s) Banksville School District(s) Byram Hills

Is any portion of subject property abutting or located within five hundred (500) feet of the following:  
The boundary of any city, town or village?

No X Yes (adjacent) \_\_\_\_\_ Yes (within 500 feet) \_\_\_\_\_

If yes, please identify name(s): \_\_\_\_\_

The boundary of any existing or proposed County or State park or any other recreation area?

No X Yes (adjacent) \_\_\_\_\_ Yes (within 500 feet) \_\_\_\_\_

The right-of-way of any existing or proposed County or State parkway, thruway, expressway, road or highway?

No X Yes (adjacent) \_\_\_\_\_ Yes (within 500 feet) \_\_\_\_\_

The existing or proposed right-of-way of any stream or drainage channel owned by the County or for which the County has established channel lines?

No X Yes (adjacent) \_\_\_\_\_ Yes (within 500 feet) \_\_\_\_\_

The existing or proposed boundary of any county or State owned land on which a public building or institution is situated?

No X Yes (adjacent) \_\_\_\_\_ Yes (within 500 feet) \_\_\_\_\_

The boundary of a farm operation located in an agricultural district?

No X Yes (adjacent) \_\_\_\_\_ Yes (within 500 feet) \_\_\_\_\_

Does the Property Owner or Applicant have an interest in any abutting property?

No X Yes \_\_\_\_\_ However, a related entity owns abutting property.

If yes, please identify the tax map designation of that property:

109.01-1-25 (related entity parcel)



**III. DESCRIPTION OF PROPOSED DEVELOPMENT**

Proposed Use: Accessory Residential - renovation of existing pool, retention of path, golf tee (no changes proposed)

Gross Floor Area: Existing N/A S.F. Proposed N/A S.F.

Proposed Floor Area Breakdown: N/A

Retail \_\_\_\_\_ S.F.; Office \_\_\_\_\_ S.F.;

Industrial \_\_\_\_\_ S.F.; Institutional \_\_\_\_\_ S.F.;

Other Nonresidential \_\_\_\_\_ S.F.; Residential \_\_\_\_\_ S.F.;

Number of Dwelling Units: \_\_\_\_\_

Number of Parking Spaces: Existing \_\_\_\_\_ Required \_\_\_\_\_ Proposed \_\_\_\_\_

Number of Loading Spaces: Existing \_\_\_\_\_ Required \_\_\_\_\_ Proposed \_\_\_\_\_

Earthwork Balance: Cut N/A C.Y. Fill N/A C.Y. No disturbance proposed

Will Development on the subject property involve any of the following:

Areas of special flood hazard? No X Yes \_\_\_\_\_

(If yes, application for a Development Permit pursuant to Chapter 177 of the North Castle Town Code may also be required)

Trees with a diameter at breast height (DBH) of 8" or greater?

No X Yes \_\_\_\_\_

(If yes, application for a Tree Removal Permit pursuant to Chapter 308 of the North Castle Town Code may also be required.)

Town-regulated wetlands? No \_\_\_\_\_ Yes X (Application has been filed)\

(If yes, application for a Town Wetlands Permit pursuant to Chapter 340 of the North Castle Town Code may also be required.)

State-regulated wetlands? No \_\_\_\_\_ Yes X

(If yes, application for a State Wetlands Permit may also be required.)

#### **IV. SUBMISSION REQUIREMENTS**

The site development plan application package shall include all materials submitted in support of the application, including but not limited to the application form, plans, reports, letters and SEQR Environmental Assessment Form. **Submission of the following shall be required:**

- One (1) PDF set of the site development plan application package in a single PDF file .
- A check for the required application fee and a check for the required Escrow Account, both made payable to "Town of North Castle" in the amount specified on the "Schedule of Application Fees."

(continued next page)

**V. INFORMATION TO BE INCLUDED ON SITE DEVELOPMENT PLAN**

See Plans prepared by Bibbo Associates, LLP, dated 9-11-2023 (Drawing EX-1, W-M1 and EC-1, previously submitted.

The following checklist is provided to enable the Applicant to determine if he/she has provided enough information on the site development plan for the Planning Board to review his/her proposal. Applicants are advised to review ARTICLE VIII, Site Development Plan of the North Castle Town Code for a complete enumeration of pertinent requirements and standards prior to making application for site development plan approval.

The application for site development plan approval will not be accepted for Planning Board review unless all items identified below are supplied and **so indicated with a check mark in the blank line provided**. If a particular item is not relevant to the subject property or the development proposal, **the letters "NA" should be entered instead**. In addition, the project will not be scheduled on a Planning Board agenda until the Applicant receives an initialed "site plan checklist" from the Planning Department.

The information to be included on a site development plan shall include:

**Legal Data:**

- Name of the application or other identifying title.
- Name and address of the Property Owner and the Applicant, (if different).
- Name, address and telephone number of the architect, engineer or other legally qualified professional who prepared the plan.
- Names and locations of all owners of record of properties abutting and directly across any and all adjoining streets from the subject property, including the tax map designation of the subject property and abutting and adjoining properties, as shown on the latest tax records.
- Existing zoning, fire, school, special district and municipal boundaries.
- Size of the property to be developed, as well as property boundaries showing dimensions and bearings as determined by a current survey; dimensions of yards along all property lines; name and width of existing streets; and lines of existing lots, reservations, easements and areas dedicated to public use.
- N/A Reference to the location and conditions of any covenants, easements or deed restrictions that cover all or any part of the property, as well as identification of the document where such covenants, easements or deed restrictions are legally established.
- N/A Schedule of minimum zoning requirements, as well as the plan's proposed compliance with those requirements, including lot area, frontage, lot width, lot depth, lot coverage, yards, off-street parking, off-street loading and other pertinent requirements.
- Locator map, at a convenient scale, showing the Applicant's entire property in relation to surrounding properties, streets, etc., within five hundred (500) feet of the site.
- North arrow, written and graphic scales, and the date of the original plan and all revisions, with notation identifying the revisions.
- A signature block for Planning Board endorsement of approval.

**Existing Conditions Data:**

- X Location of existing use and design of buildings, identifying first floor elevation, and other structures.
- N/A Location of existing parking and truck loading areas, with access and egress drives thereto.
- X Location of existing facilities for water supply, sanitary sewage disposal, storm water drainage, and gas and electric service, with pipe sizes, grades, rim and inverts, direction of flow, etc. indicated.
- X Location of all other existing site improvements, including pavement, walks, curbing, retaining walls and fences.
- N/A Location, size and design of existing signs.
- N/A Location, type, direction, power and time of use of existing outdoor lighting.
- N/A Location of existing outdoor storage, if any.
- X Existing topographical contours with a vertical interval of two (2) feet or less.
- X Location of existing floodplains, wetlands, slopes of 15% or greater, wooded areas, landscaped areas, single trees with a DBH of 8" or greater, rock outcrops, stone walls and any other significant existing natural or cultural features.

**Proposed Development Data:**

- N/A Proposed location of lots, streets, and public areas, and property to be affected by proposed easements, deed restrictions and covenants.
- N/A Proposed location, use and architectural design of all buildings, including proposed floor elevations and the proposed division of buildings into units of separate occupancy.
- X Proposed means of vehicular and pedestrian access to and egress from the site onto adjacent streets.
- N/A Proposed sight distance at all points of vehicular access.
- N/A Proposed number of employees for which buildings are designed
- N/A Proposed streets, with profiles indicating grading and cross-sections showing the width of the roadway; the location and width of sidewalks; and the location and size of utility lines.
- N/A Proposed location and design of any pedestrian circulation on the site and off-street parking and loading areas, including handicapped parking and ramps, and including details of construction, surface materials, pavement markings and directional signage.
- X Proposed location and design of facilities for water supply, sanitary sewage disposal, storm water drainage, and gas and electric service, with pipe sizes, grades, rim and inverts, direction of flow, etc. indicated.

- X   Proposed location of all structures and other uses of land, such as walks, retaining walls, fences, designated open space and/or recreation areas and including details of design and construction.
- N/A   Location, size and design of all proposed signs.
- N/A   Location, type, direction, power and time of use of proposed outdoor lighting.
- N/A   Location and design of proposed outdoor garbage enclosure.
- N/A   Location of proposed outdoor storage, if any.
- X   Location of proposed landscaping and buffer screening areas, including the type (scientific and common names), size and amount of plantings.
- N/A   Type of power to be used for any manufacturing
- N/A   Type of wastes or by-products to be produced and disposal method
- N/A   In multi-family districts, floor plans, elevations and cross sections
- N/A   The proposed location, size, design and use of all temporary structures and storage areas to be used during the course of construction.
- N/A   Proposed grade elevations, clearly indicating how such grades will meet existing grades of adjacent properties or the street.
- X   Proposed soil erosion and sedimentation control measures.
- N/A   For all proposed site development plans containing land within an area of special flood hazard, the data required to ensure compliance with Chapter 177 of the North Castle Town Code.
- N/A   For all proposed site development plans involving clearing or removal of trees with a DBH of 8" or greater, the data required to ensure compliance with Chapter 308 of the North Castle Town Code.
- X   For all proposed site development plans involving disturbance to Town-regulated wetlands, the data required to ensure compliance with Chapter 340 of the North Castle Town Code.

# WETLANDS AND DRAINAGE APPLICATION TOWN OF NORTH CASTLE BUILDING DEPARTMENT

DATE: 9/11/2023

\$50 (min.) for Residential Apps.  
\$250 (min.) for Commercial Apps.

FEE: \$ 50.00 (subject to additional fees as determined by the Planning Department)

1. **NAME & ADDRESS OF APPLICANT:** Round Hill Land Corp.  
c/o Michael Lehrer  
92 Round Hill Road  
Armonk, NY 10504  
TELEPHONE: ( 914 ) 421 - 1800  
Hocherman Tortorella & Wekstein, LLP - Geraldine N. Tortorella, Esq.  
(Attorney)

**OWNER (IF DIFFERENT):** Same

2. **STREET ADDRESS OF PROPERTY:** 94 Round Hill Road  
SECTION: 109.01 BLOCK: 1 LOT: 24

3. **DESCRIPTION OF PROPOSED WORK & MATERIALS: PLANS & SPECIFICATIONS ANNEXED HERETO. STATE NAME AND OCCUPATION OF PREPARER:**  
See Plans prepared by Bibbo Associates, LLP, submitted herewith, dated September 11, 2023.

4. **IMPACT STATEMENT (IF REQUIRED) PREPARED BY:** See Wetland Functional Analysis, prepared by Pfizer-Jäehinig, dated September \_\_\_\_\_, 2023.

DATED: 9/11/2023

APPLICANT'S SIGNATURE:   
By: Michael Lehrer, President

**NOTE:** WETLANDS APPLICATIONS WILL BE REVIEWED BY THE TOWN BOARD, THE PLANNING BOARD, THE CONSERVATION BOARD, OR THE TOWN ENGINEER AT THE DISCRETION OF THE TOWN ENGINEER.

Do you have any intention of tearing down a house to build a new house within the next SIX (6) months?  
 Yes  No

Do you have any intention to expand a house over 1500 square feet within the next SIX (6) months?  
 Yes  No

If the Planning Board has granted you approval previously, on what dates were you approved? (List Below)  
Prior approval granted by Town Engineer for pool and related construction following review by Conservation Board, Wetland Permit#E93-8, dated October 12, 1993.



September 11, 2023

*Via Electronic Mail ([jhuerta@northcastleny.com](mailto:jhuerta@northcastleny.com))*

Hon. Christopher Carthy, Chairman  
and Members of the Planning Board  
Town Hall Annex  
17 Bedford Road  
Armonk, New York 10504

*Re: (i) Application of Round Hill Land Corp. for Wetland Permit for Pool Renovation, Access Path & Tee*

*Property: 94 Round Hill Road, Town of North Castle  
Tax Identification No.: Section 109.01, Block 01, Lot 24*

*(ii) Application of Michael Lehrer for Wetland Permit to Reconstruct and Expand Golf Green, Tees, Access Path & Storage Shed*

*Property: 92 Round Hill Road, Town of North Castle  
Tax Identification No.: Section 109.01, Block 01, Lot 25*

Dear Chairman Carthy and Members of the Planning Board:

This firm represents Round Hill Land Corp. (the “Corporation”), owner of the property at 94 Round Hill Road (the “94 Property”) and Michael Lehrer (“Lehrer”), owner of the property at 92 Round Hill Road (the “92 Property”). Both Properties are developed with single family residences and related accessory uses and improvements. The 94 Property also contains an inground swimming pool and surrounding deck for which a wetland permit was issued by the Town Engineer in 1993. The 92 Property is improved with a golf green, tees and related improvements for which an administrative wetland permit was issued in 1998.

The 92 Property lies to the north of the 94 Property. A wetland originating offsite enters the 92 Property from the north, extends across the 94 Property and continues offsite to the south, bisecting the rears of the Properties from the residences and their immediate surroundings. Pursuant to the 1993 wetland permit, a wetland crossing was constructed on the 92 Property; it provides limited access to the rear of that Property (east of the wetland) where two existing golf tees are located.<sup>1</sup>

In 2022, the Corporation commenced efforts to repair the existing swimming pool and, to facilitate access, scraped and widened a path along the west side of the wetlands and removed the existing chain link fencing along the wetland boundary. The Corporation also roughed out a path on the east side of the wetlands to obtain access to the lands located there and a rock outcropping that had been fashioned into a tee. Violations were issued for the work because the building department considered the pool repair work to be a renovation and believed that some filling of the wetland occurred in connection with the access paths, but no building or wetland permits had been issued.

<sup>1</sup> A third tee on the east side of the wetland lies on the 94 Property. The tees are rock outcroppings loosely covered with artificial turf.

Hon. Chris Carthy, Chairman  
and Members of the Planning Board  
September 11, 2023  
Page 2

The violations were resolved through a plea agreement, which requires, in part, that the Corporation obtain approvals for the work that the Corporation proposes to retain on the 94 Property and restoration and mitigation associated therewith. The Corporation's application is made, in part, to comply with the requirements of the plea agreement.

The Corporation desires to retain a path along the rear of the pool and residence on the 94 Property for reasonable access to the pool and the retaining wall supporting it, for repairs and renovations; the path would also serve as a means of access between the 92 and 94 Properties. It also seeks access to the rear of the 94 Property over the existing wetland crossing and path on the 92 Property and the roughed-out path on the 94 Property. On the recommendation of the Corporation's wetland and engineering consultants (Pfizer-Jaehnic Environmental Consulting and Bibbo Associates, LLP, ), the Corporation proposes to narrow the width of the access paths to 5-6 feet, convert the path along the western side of the wetland to wood chips and the section on the eastern side of the wetland to gravel, replant the area between the edge of the path and the wetland proper with a wetland mix and reinstall the chain link fencing along the western wetland boundary. The Corporation also proposes to complete the pool renovation work, access to which would be from the wood-chip access path. These proposed activities will not require any grading or result in new impervious surfaces.

Wetland and Soil Scientist Mary Jaehnic concludes in the Wetland Functional Analysis, submitted herewith, that the activities that have already occurred on the 94 Property, those that are proposed and the uses and improvements that will remain have and will not adversely affect the function or condition of the wetland on the 94 Property provided the proposed mitigation (described above) is implemented.

In the course of dealing with the violations on the 94 Property on behalf of the Corporation, Lehrer came to appreciate that even though the golf green and tees had previously been approved, a permit should be sought to reconstruct them and establish the additional paths. With respect to the 92 Property, Lehrer seeks approval to renovate and expand the existing golf green, using sand and porous, low maintenance, artificial turf on the green and other areas to stabilize them, maintain an approximately 5-6 foot wide wood-chip path along the west side of the wetlands for access between the 92 and 94 Properties and a gravel path around the east side of the wetland to reach the upland portions of the 92 and 94 Properties, retain the tees and retain a residential storage shed that had previously been placed on the west side of the wetland for tools and other equipment. As part of the application for the 92 Property, Lehrer is proposing to narrow the existing paths and restore and replant the wetland edge with wetland seed mix and tall fescue grass and goldenrod.

A minor amount of grading is required to complete the work; potential impacts associated therewith will be mitigated by the installation of erosion control measures between the area of grading and the wetland.

According to the Wetland Functional Analysis, the proposed improvements and uses on the 92 Property will not adversely affect the function of the wetlands provided the foregoing mitigation is installed.



Hon. Chris Carthy, Chairman  
and Members of the Planning Board  
September 11, 2023  
Page 3

Submitted herewith are the following items in support of the applications:

1. Wetland Permit Application for the 94 Property;
2. Wetland Permit Application for the 92 Property;<sup>2</sup>
3. Plans prepared by Bibbo Associates LLP (three sheets showing existing conditions, wetland mitigation and erosion controls), dated September 11, 2023;
4. Wetland Functional Analysis, prepared by Pfizer-Jaehnig Environmental Consulting, dated September 8, 2023; and
5. Short Environmental Assessment Form.<sup>3</sup>

Checks from the Corporation and Lehrer, in the amount of \$50 each, for the minimum application fees are being sent by mail. (We understand that additional fees will be required and ask that you notify us of the additional amounts for which payment will be sent by our client.)

We would appreciate it if the Board would schedule this matter for its next available meeting so that we can start a discussion about our client's goals and objectives and proposed means of achieving them. We look forward to working with the Board to resolve these matters.

Respectfully yours,

Hocherman Tortorella & Wekstein, LLP

By:

  
Geraldine N. Tortorella

GNT:hc

Enclosures

cc: *(via electronic mail with enclosures)*

Robert Melillo, Building Inspector  
Adam Kaufman, AICP  
Roland Baroni, Jr., Esq.  
Tim Allen, P.E.  
Mary Jaehnig  
Round Hill Land Corp.  
Mr. Michael Lehrer

*(via electronic mail without enclosures)*

Patrick J. Bliss, Esq

S:\# MATTERS\Round Hill 0373\Plea Agreement 001\Letters\Planning Board 9-11-2023.docx

<sup>2</sup> The 92 and 94 Properties are in single and separate ownership but because the owners are related, the access paths at issue provide access between the Properties and the same wetland system is involved, we submit the applications together for consideration.

<sup>3</sup> We believe that because these applications concern single-family residential improvements, they are Type II actions exempt from SEQRA.

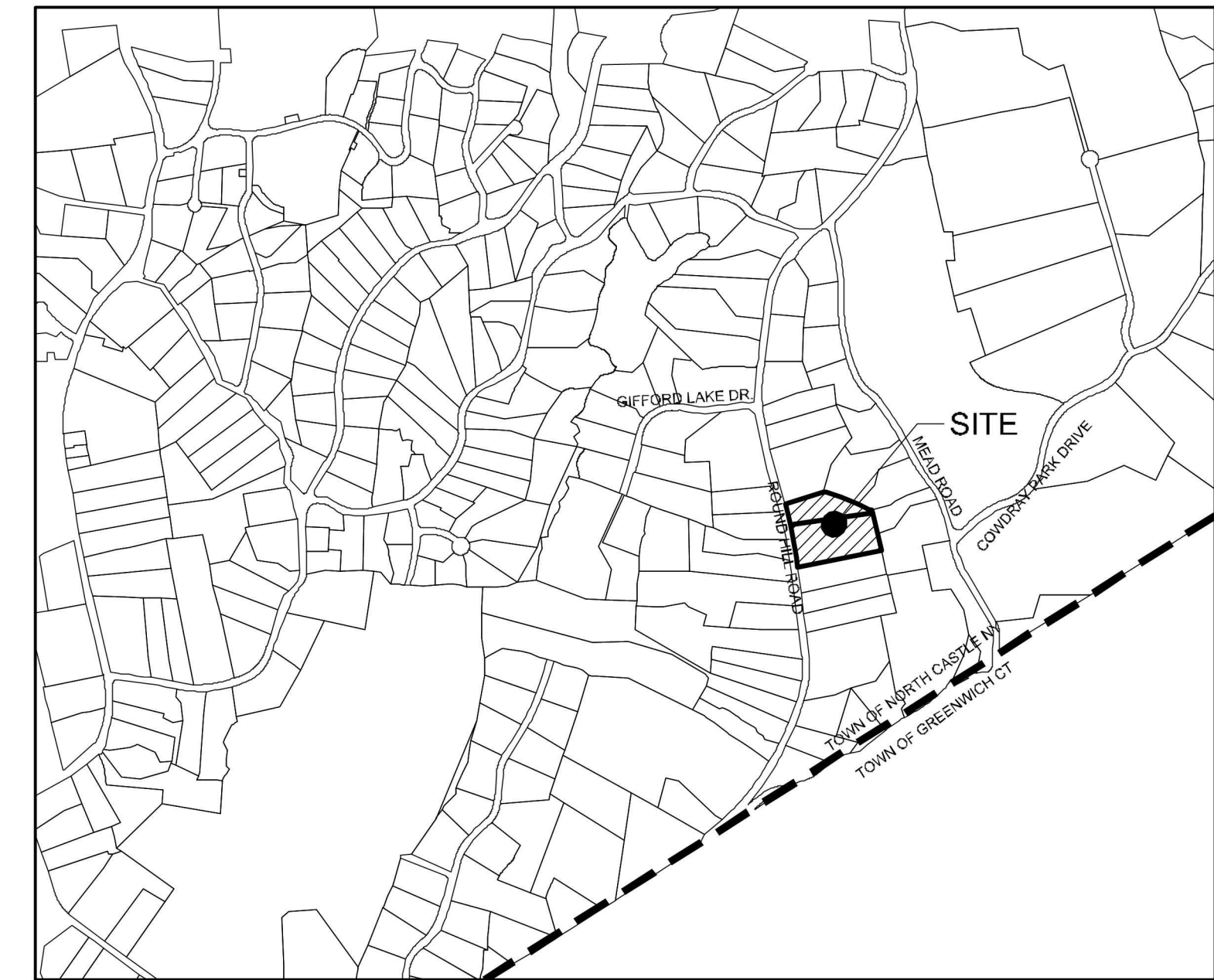
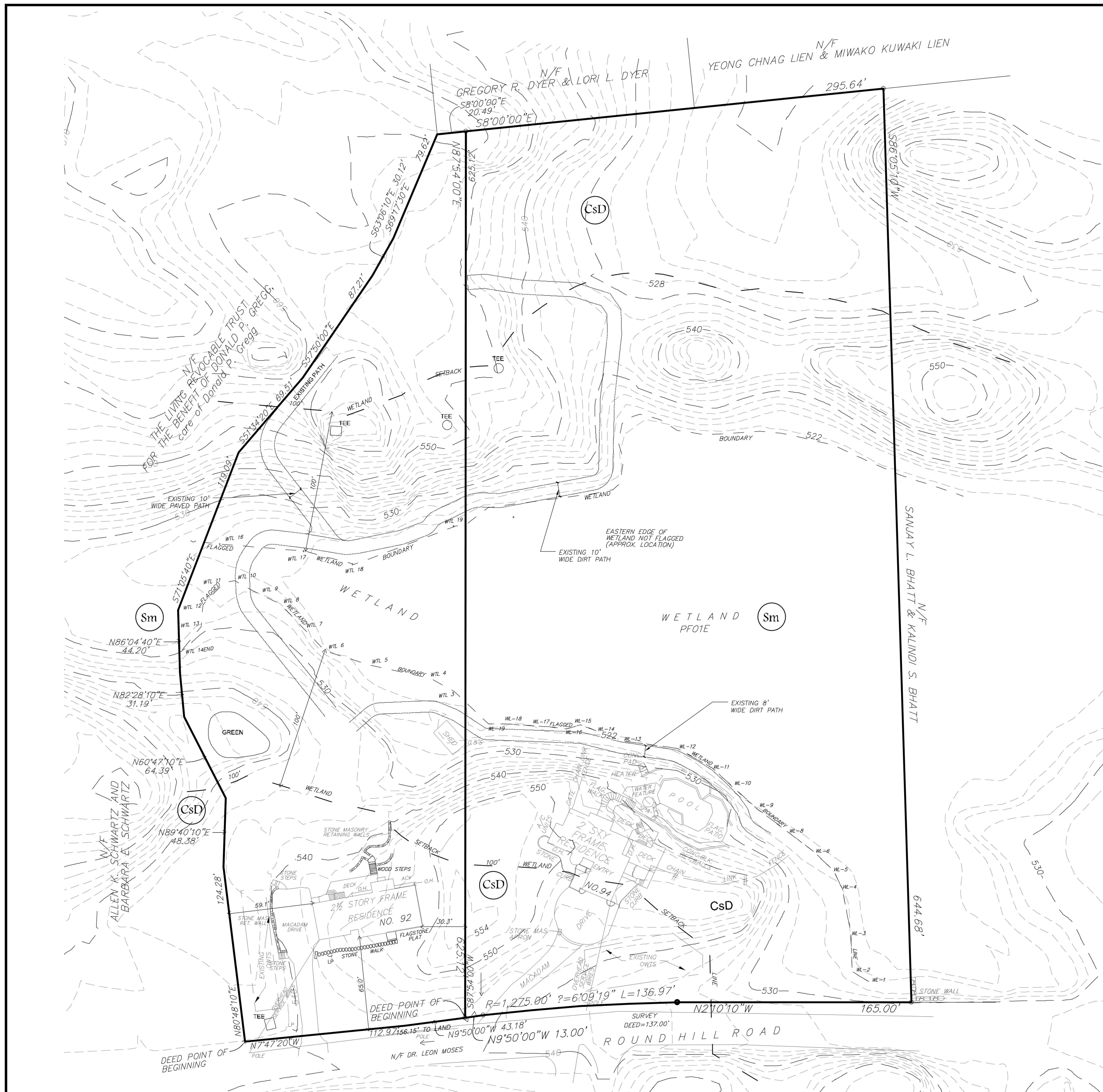

**LOCATION MAP**  
N.T.S.

**PROJECT INFORMATION:**

- OWNER/APPLICANT:  
 ROUND HILL LAND CORP.  
 94 ROUND HILL ROAD  
 NORTH CASTLE, NY 10504  
 MICHAEL J. LEHRER  
 92 ROUND HILL ROAD  
 NORTH CASTLE, NY 10504
- TOTAL AREA : 4.413 ACRES + 2.086 ACRES
- TAX ID # SECTION 109.01, BLOCK 1 LOT 24 & 25
- ZONING DISTRICT: R-2A
- NORTH CASTLE WATER SHED MAP: BYRAM RIVER BASIN
- SURVEY INFORMATION BY:  
 H STANLEY JOHNSON & COMPANY  
 LAND SURVEYORS, P.C.  
 42 SMITH AVENUE P.O. BOX 93  
 MT. KISCO, NY 10549

SURVEY DATE: 94 ROUND HILL ROAD MARCH 15, 2023  
 92 ROUND HILL ROAD MAY 10, 2023

WETLAND FLAGGED: MARY JAEHNIC  
 17 FAIRVIEW AVE.  
 RIDGEFIELD, CT 06377

94 ROUND HILL ROAD: 2-27-2023  
 92 ROUND HILL ROAD: 5-4-2023

**PLAN**  
GRAPHIC SCALE

**LEGEND:**

- EXISTING PROPERTY LINE
- EXISTING 2' CONTOUR
- EXISTING 10' CONTOUR
- SOIL BOUNDARY LINE

UNAUTHORIZED ALTERATIONS AND ADDITIONS TO THIS DRAWING IS A VIOLATION OF SECTION 2302.02 OF THE NEW YORK STATE EDUCATION LAW.  
 COPYRIGHT © 2023 BIBBO ASSOCIATES, LLP ALL RIGHTS RESERVED. UNAUTHORIZED REPRODUCTION IS A VIOLATION OF APPLICABLE LAW.

APPROVED BY THE TOWN OF NORTH CASTLE  
 PLANNING BOARD RESOLUTION, DATED: \_\_\_\_\_

ENGINEERING DRAWING PLANS REVIEWED BY TOWN ENGINEER  
 REVIEWED BY TOWN ENGINEER \_\_\_\_\_

JOSEPH M. CERMELE, P.E.  
 KELLARD SESSIONS CONSULTING, P.C.  
 CONSULTING TOWN ENGINEERS

CHRISTOPHER CARTHAY, CHAIR

REVISIONS		DATE	DESCRIPTION	BY/CK	DATE	DESCRIPTION	BY/CK

**EXISTING CONDITIONS**

**MICHAEL LEHRER/ROUND HILL RD CORP.**  
 92-94 ROUND HILL ROAD  
 TOWN OF NORTH CASTLE, WESTCHESTER COUNTY 10504

DATE: 9-11-2023  
 SCALE: 1" = 40'  
 FILE: \*\*  
 DSGN / CHK: TA  
 DRN. BY: DK / RAL / AW  
 SHT NO. 1 OF 3  
 DWG NO. **EX-1**

**BIBBO ASSOCIATES, LLP**  
 293 ROUTE 100 SUITE 203  
 SOMERS, NEW YORK 10589  
 TEL. 914 277 5805

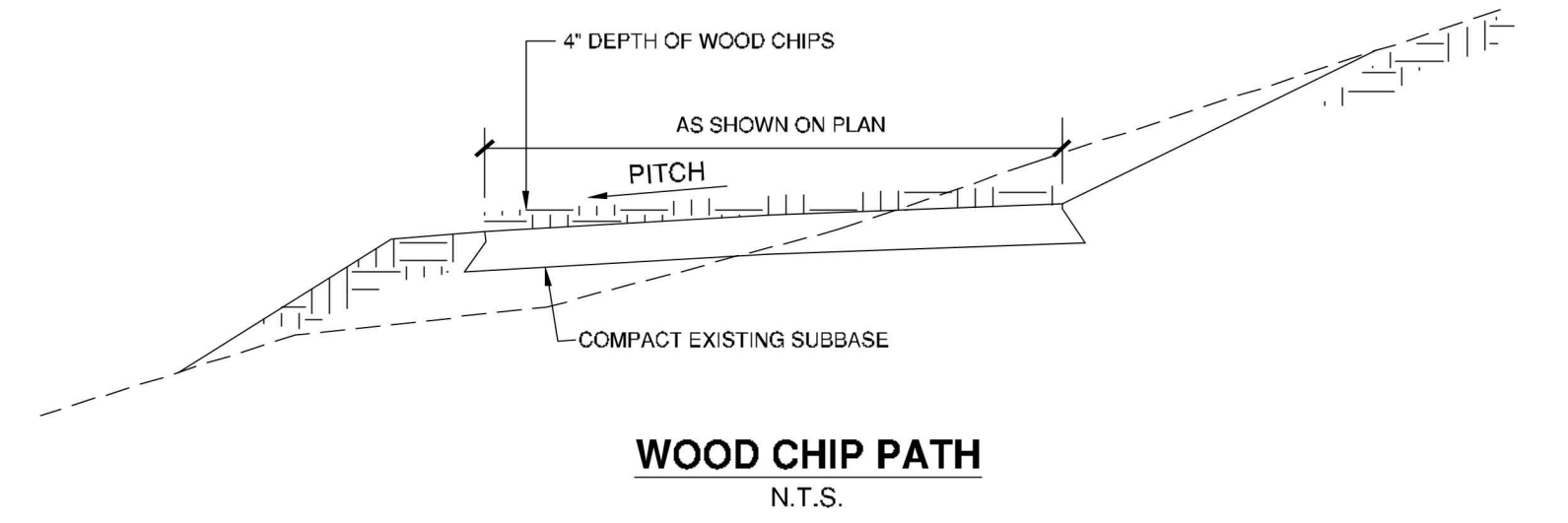
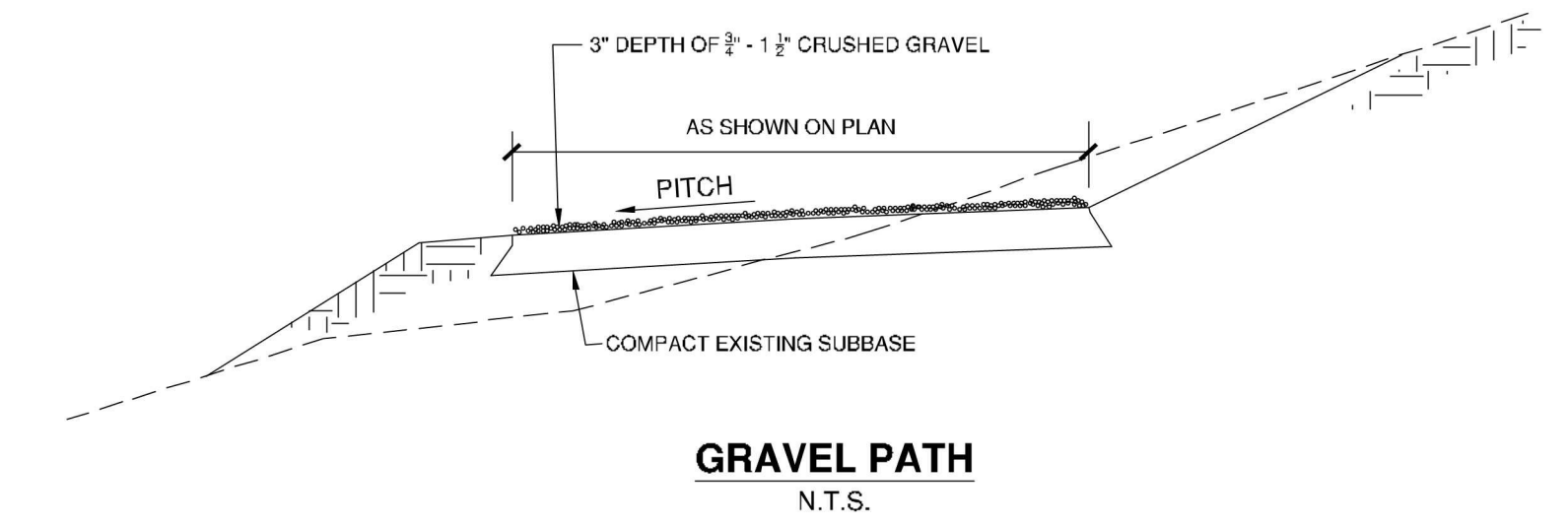

**LEGEND:**  
 EXISTING PROPERTY LINE ———  
 EXISTING 2' CONTOUR - - - - -  
 EXISTING 10' CONTOUR - - - - -

APPROVED BY THE TOWN OF NORTH CASTLE  
 PLANNING BOARD RESOLUTION, DATED: \_\_\_\_\_

ENGINEERING DRAWING PLANS REVIEWED BY TOWN ENGINEER  
 REVIEWED BY TOWN ENGINEER \_\_\_\_\_

JOSEPH M. CERMELE, P.E.  
 KELLARD SESSIONS CONSULTING, P.C.  
 CONSULTING TOWN ENGINEERS

CHRISTOPHER CARTHY, CHAIR

UNAUTHORIZED ALTERATIONS AND ADDITIONS TO THIS DRAWING IS A VIOLATION OF SECTION 2302, (2) OF THE NEW YORK STATE EDUCATION LAW.

COPYRIGHT © 2023 BIBBO ASSOCIATES, LLP  
 ALL RIGHTS RESERVED. UNAUTHORIZED REPRODUCTION IS A VIOLATION OF APPLICABLE LAWS.

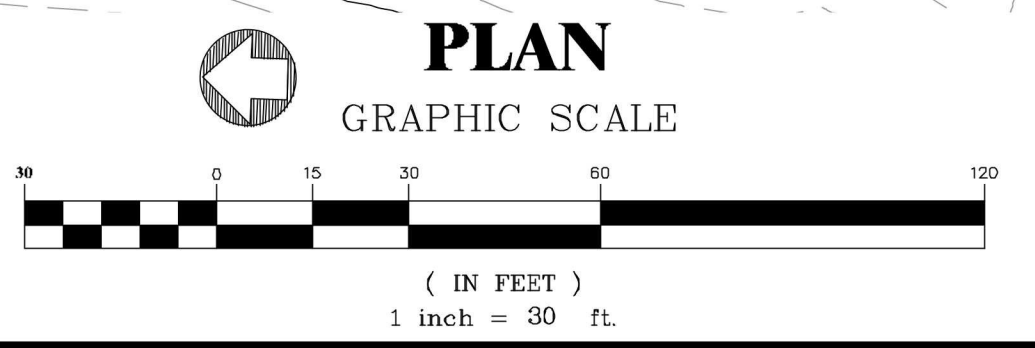

DATE	DESCRIPTION	BY/CHK	DATE	DESCRIPTION	BY/CHK

	<b>WETLAND MITIGATION</b> MICHAEL LEHRER/ROUND HILL RD CORP. 92-94 ROUND HILL ROAD TOWN OF NORTH CASTLE, WESTCHESTER COUNTY 10504	DATE: 9-11-2023 SCALE: 1" = 30' FILE: ** DSGN / TA CHK: TA DRN. BY: DK / RAL / AW SHT NO. 2 OF 3 DWG NO. <b>WM-1</b>
	<b>BIBBO ASSOCIATES, LLP</b> 293 ROUTE 100 SUITE 203 SOMERS, NEW YORK 10589 TEL. 914 277 5805	

P:\Projects\Lehrer\DWG\LEHRER-WETLAND 9-2023.dwg, 9/11/2023 11:24:22 AM, R:\mrametagne, 1:1

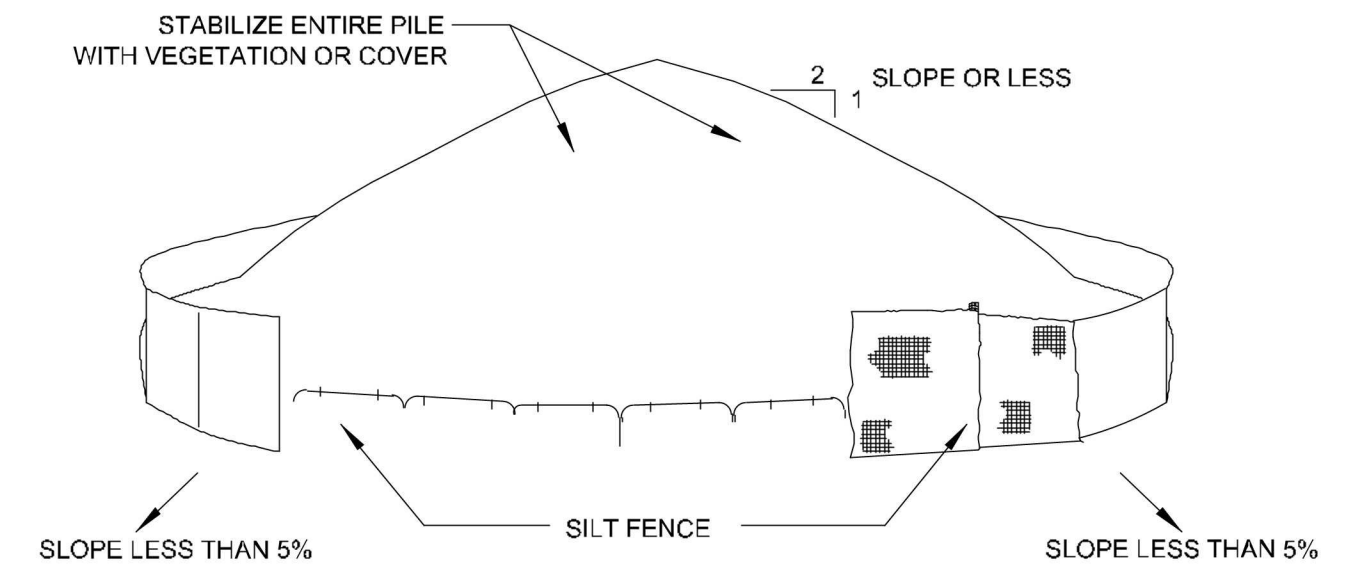
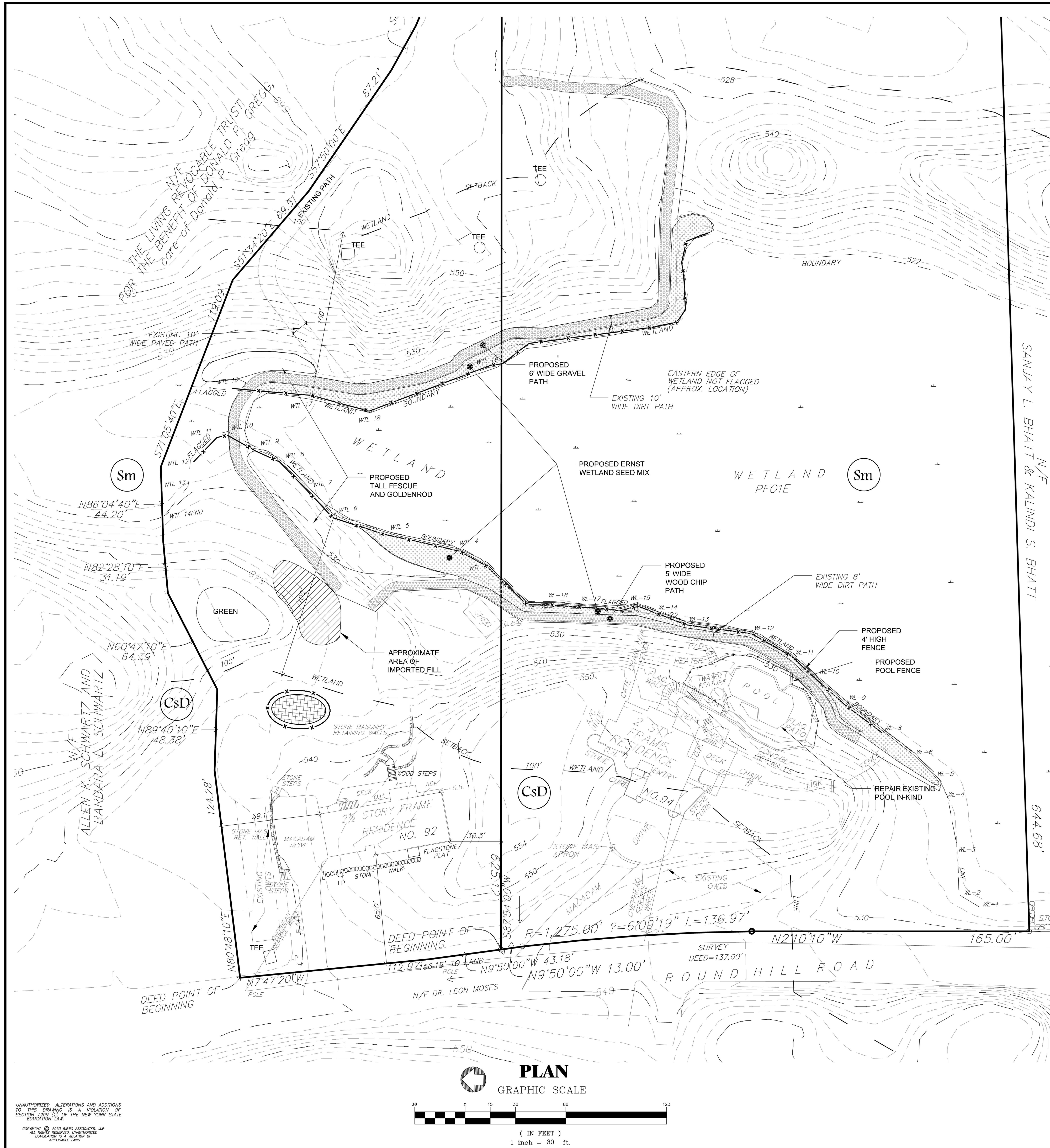

- INSTALLATION NOTES:**
1. AREA CHOSEN FOR STOCKPILING OPERATIONS SHALL BE DRY AND STABLE
  2. MAXIMUM SLOPE OF STOCKPILING SHALL BE 1:2
  3. UPON COMPLETION OF SOIL STOCKPILING, EACH PILE SHALL BE SURROUNDED WITH SILT FENCING, THEN STABILIZED WITH VEGETATION OR COVERED.
  4. SEE SILTATION FENCE DETAIL.

**SOIL STOCKPILE DETAIL**  
N. T. S.

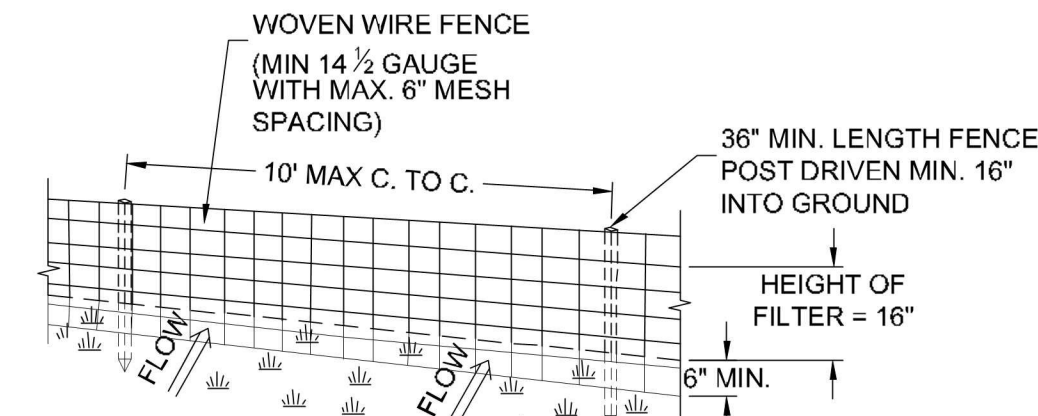

**PERSPECTIVE VIEW**

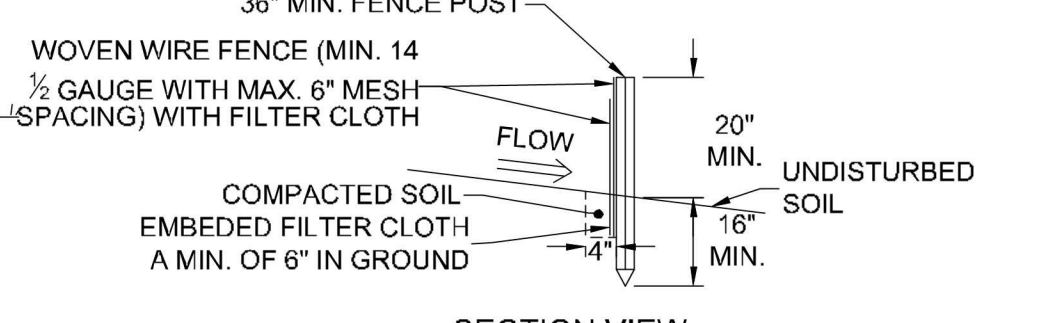

**SECTION VIEW**

- CONSTRUCTION SPECIFICATIONS:**
1. WOVEN WIRE FENCE TO BE FASTENED SECURELY TO FENCE POSTS WITH WIRE TIES OR STAPLES. POSTS SHALL BE STEEL WITH "T" OR "U" TYPE OR HARDWOOD
  2. FILTER CLOTH TO BE FASTENED SECURELY TO WOVEN WIRE FENCE WITH TIES SPACED EVERY 24" AT TOP AND MID SECTION. FENCE SHALL BE WOVEN WIRE, 6" MAXIMUM MESH OPENING.
  3. WHEN TWO SECTIONS OF FILTER CLOTH ADJOIN EACH OTHER THEY SHALL BE OVERLAPPED BY SIX INCHES AND FOLDED. FILTER CLOTH SHALL BE EITHER FILTER X, MIRAFI 100X, STABILINKA T140N, OR APPROVED EQUIVALENT.
  4. PREFABRICATED UNITS SHALL BE GEOFAB, ENVIROFENCE, OR APPROVED EQUIVALENT.
  5. MAINTENANCE SHALL BE PERFORMED AS NEEDED AND MATERIAL REMOVED WHEN "BULGES" DEVELOP IN THE SILT FENCE.

**SILT FENCE DETAIL**  
N. T. S.

**LEGEND:**

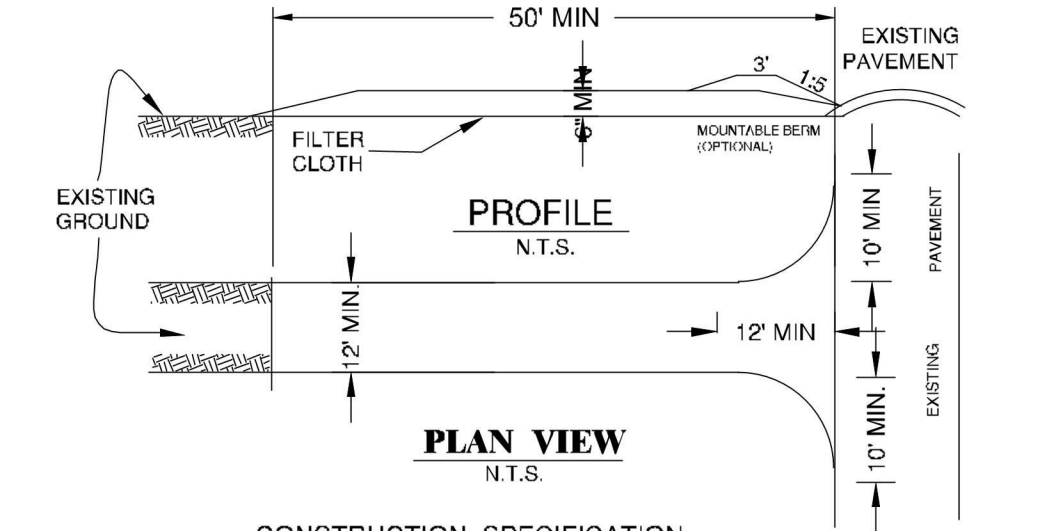
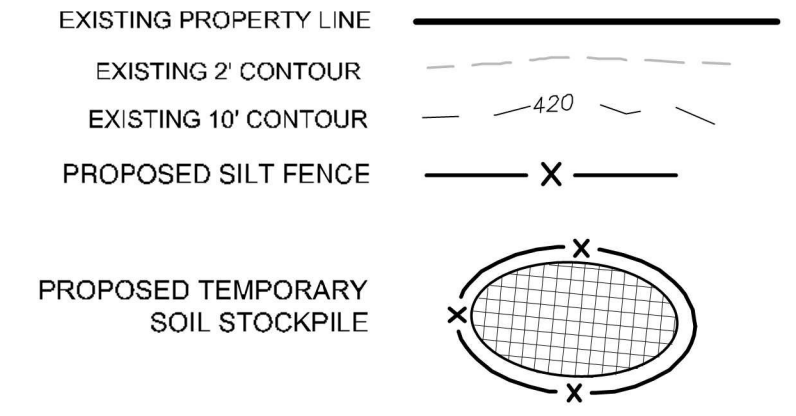

- CONSTRUCTION SPECIFICATION**
1. STONE SIZE: USE 2" STONE, OR RECYCLED CONCRETE EQUIVALENT.
  2. LENGTH LESS THAN 50' (EXCEPT ON A SINGLE RESIDENCE LOT WHERE A 30 FOOT MINIMUM LENGTH WOULD APPLY.)
  3. THICKNESS: NOT LESS THAN SIX (6) INCHES.
  4. WIDTH: TWELVE (12) FOOT MINIMUM, BUT NOT LESS THAN THE FULL WIDTH AT POINTS WHERE INGRESS OR EGRESS OCCURS. TWENTY-FOUR (24) FOOT IF SINGLE ENTRANCE TO SITE.
  5. FILTER CLOTH: WILL BE PLACED OVER THE ENTIRE AREA PRIOR TO PLACING OF STONE.
  6. SURFACE WATER: ALL SURFACE WATER FLOWING OR DIVERTED TOWARD CONSTRUCTION ENTRANCES SHALL BE PIPED ACROSS THE ENTRANCE. IF PIPING IS IMPRACTICAL, A MOUNTABLE BERM WITH 5:1 SLOPES WILL BE PERMITTED.
  7. MAINTENANCE: THE ENTRANCE SHALL BE MAINTAINED IN A CONDITION WHICH PREVENT TRACKING OR FLOWING OF SEDIMENT ONTO PUBLIC RIGHTS-OF-WAY. ALL SEDIMENT SPILLED, DROPPED, WASHED OR TRACKED ONTO PUBLIC RIGHTS-OF-WAY MUST BE REMOVED IMMEDIATELY.
  8. WHEN WASHING IS REQUIRED, IT SHALL BE DONE ON AN AREA STABILIZED WITH STONE & WHICH DRAINS INTO AN APPROVED SEDIMENT TRAPPING DEVICE.
  9. PERIODIC INSPECTION AND NEEDED MAINTENANCE SHALL BE PROVIDED AFTER EACH RAIN.

**STABILIZED CONSTRUCTION ENTRANCE DETAIL**  
N. T. S.

APPROVED BY THE TOWN OF NORTH CASTLE PLANNING BOARD RESOLUTION, DATED: \_\_\_\_\_

ENGINEERING DRAWING PLANS REVIEWED BY TOWN ENGINEER REVIEWED BY TOWN ENGINEER

\_\_\_\_\_  
DATE

JOSEPH M. CERMELE, P.E.  
KELLARD SESSIONS CONSULTING, P.C.  
CONSULTING TOWN ENGINEERS

\_\_\_\_\_  
DATE

CHRISTOPHER CARTHY, CHAIR

REVISIONS	DATE	DESCRIPTION	BY/CK	DATE	DESCRIPTION	BY/CK

**EROSION CONTROL PLAN**

**MICHAEL LEHRER/ROUND HILL RD CORP.**  
92-94 ROUND HILL ROAD  
TOWN OF NORTH CASTLE, WESTCHESTER COUNTY 10504

DATE: 9-11-2023  
SCALE: 1" = 30'  
FILE: \*\*  
DSGN / CHK: TA  
DRN. BY: DK / RAL / AW  
SHT NO: 3 OF 3  
DWG NO: **EC-1**

**BIBBO ASSOCIATES, LLP**  
293 ROUTE 100 SUITE 203  
SOMERS, NEW YORK 10589  
TEL. 914 277 5805

September 8, 2023

Michael Lehrer  
92 Round Hill Road  
Town of North Castle, NY

Round Hill Property Corp.  
94 Round Hill Road  
Town of North Castle, NY

**Wetland Functional Analysis: 94 Round Hill Road & 92 Round Hill Road**

Setting:

The two residential properties are located on the eastern side of Round Hill Road and are both developed with single family dwellings and accessory structures and uses. An inground swimming pool and decking exist on 94 Round Hill Road; golf greens and related golf improvements and a shed exist on 92 Round Hill Road.

The topography descends from the dwellings to a central depression on both lots and ascends to the east past the wetland edge. The wetland originates approximately 600 feet to the north. The site wetlands are located near the beginning of a watershed to Wilshire Pond Brook that enters Converse Pond Brook and eventually East Branch Byram River and Long Island Sound.

The wetlands are both locally and state regulated, designated K-30 by the New York State Department of Environmental Conservation.

An intermittent watercourse within a wooded wetland flows into the wetland at 92 Round Hill Road. The watercourse enters a scrub/shrub wetland densely vegetated by phragmites. The wetland continues onto 94 Round Hill Road but becomes wooded with a closed canopy. The wetland extends

**PFIZER – JÄHNIG**  
**ENVIRONMENTAL CONSULTING**

---

to the south and off site. A small intermittent stream from west of Round Hill Road enters the wetland near the southern property line.

The surrounding uplands are shallow to bedrock with the soil unit Chatfield-Charlton, very rocky, with areas of bedrock outcropping. The wetland has a mineral soil, Sun loam, that formed in glacial till.

Wetland Functional Analysis:

The functional analysis is based on 'A Rapid Procedure for Assessing Wetland Functional Capacity' by Dennis W. Magee and Garrett G. Hollands, 1998. The closest hydrogeomorphic classification for this wetland is depressional with an inlet and outlet and precipitation/surface water driven hydrology. The analyses are based on field observations applied to this class of wetland.

-Modification of Groundwater Discharge: low function.

The low function is due to the glacial till hydric soil versus glaciofluvial deposits and no visible seeps.

-Modification of Groundwater Recharge: high function.

The depressional shape creates long term water detention after rainfall events, some of the stored water recharges the underlying fractured bedrock aquifer.

-Storm and Flood Water Storage: high function.

The high density of vegetation adds to surface roughness reducing flow through velocity. The wetland topography is flat, aiding in storage.

-Modification of Water Quality: high function.

Inflowing water from the north and from the surrounding uplands stills upon entering the wetland and drops sediment. Dissolved solids interact biologically and are retained in wetland. High potential for detention, removal and transformation of dissolved elements and compounds in the forested wetland with continuous cover and clayey soil.

**PFIZER – JÄHNIG**  
**ENVIRONMENTAL CONSULTING**

---

-Export of Detritus: moderate function.

The wetland does contribute detritus to downstream receiving waters but conversely, retains detritus also.

-Contribution to Abundance and Diversity of Wetland Vegetation: high function.

The wetland has high density of vegetation with both phragmites stand and forested wetland. The forested wetland has a closed canopy layer, thick shrub layer and diverse groundcover with microrelief. The wetland is connected to other wetlands to both north and south. The wetland at 92 Round Hill Road has a much lower diversity of vegetation.

-Contribution to Abundance and Diversity of Wetland Fauna: high function.

The water regime is seasonally and temporarily flooded, the watershed land use is low density, connected within a larger wetland system and corridor, microrelief in wetland.

In summary, the wetland is located at the start of a headwater with relatively small watershed and is surface water driven. Most functions are high with the exception of modification of groundwater discharge and export of detritus. The wetland vegetation diversity is low on the northern property and very diverse on the southern.

Wetland Disturbances:

94 Round Hill Road:

A dirt accessway was roughed in to allow for pool repairs. The accessway is in part directly adjacent to the wetland. The route approximately follows the upland side of the remains of a chain link fence. The accessway was created by scraping a thin layer of soil and rock ledge to form a level dirt path. During the scraping, upland vegetation was removed and stones were compacted to form the path along the wetland edge.

Erosion of the path and sedimentation into the wetland has not been observed. The diversity of vegetation continues at the wetland edge.

**PFIZER – JÄHNIG**  
**ENVIRONMENTAL CONSULTING**

---

The accessway is stable and the owner would like to retain it for future access to the pool and the rear of the residence. In my opinion, retention of the accessway would not adversely impact the wetland functions, subject to implementation of mitigation including narrowing the accessway; reconstruction of the chain link fence; planting disturbed areas with wetland seed mix. The functions of the wetland have remained intact during the activity and will continue to do so with implementation of the suggested mitigation.

Roughing in of an accessway has occurred on the eastern side of the wetland. The roughing in included scraping of ledge rock and deposition into part of the wetland. Mitigation in this area would include narrowing of the accessway, removal of stone and fill from the wetland and a vegetative restoration of disturbed buffer and wetland.

92 Round Hill Road:

Historically (1999), a wetland permit was granted for construction of a golf green, wetland crossing, and accessway within the wetland and buffer. A review of aerial photographs indicate that the wetland buffer to the rear of the dwelling has been open since at least 2000. Grading has occurred in and adjacent to the wetland. The owner proposes to expand the existing golf green and cover the green with new synthetic turf and grass in all disturbed areas. A small shed had been placed within the buffer and a dirt path has been roughed in connecting the two properties. A dirt accessway has been constructed east of the wetland disturbing both wetland and upland buffer. Upland and wetland vegetation has been removed to rough in the access east of the wetland. Ledge has been scraped and graded to form a level dirt and stone access. A portion of the roughed in road is within the wetland.

The wetland has been scrub/shrub since at least 2000. In my opinion, the improvements proposed to remain will not adversely affect the wetland functions with implementation of mitigation including narrowing the new access and using permeable pavers where indicated. Wetland vegetation to be used in restoration of the disturbed wetland would include dense shrub planting to discourage further phragmites colonization. Phragmites has been established for decades and the addition of shrub plantings would improve the present function of floral and faunal diversity within the wetland.



**PFIZER – JÄHNIG**  
**ENVIRONMENTAL CONSULTING**

---

There is currently a vegetated strip along the western buffer to the wetland. Widening of a no mow area would provide additional protection to the wetland.

I understand that you will be using this Report in connection with applications to the Town of North Castle. Should additional information be required, please let me know.

Sincerely,

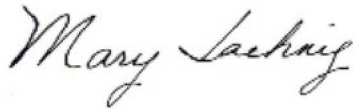

Mary Jaehnig  
soil scientist

Pfizer-Jaehnig Soils  
17 Fairview Avenue  
Ridgefield, CT 06877

## RESUME

Mary Jaehnig  
17 Fairview Avenue  
Ridgefield, Connecticut  
203 431 8113

### Professional Experience

1985-present, Environmental Consultant, Pfizer-Jaehnig Soils, Ridgefield, Ct.

Soil mapping, wetland delineations, environmental assessments, wetland functional analyses, native and invasive species inventories.

Major clients: IBM World Headquarters, Armonk, NY.  
Oneida Indian Nation, Verona, NY.  
Westchester County Airport, White Plains, NY  
Scotts Ridge Middle School, Ridgefield, CT  
Bronx River Parkway, Westchester County, NY  
Peekskill Hospital, Peekskill, NY

1984-85, Geologist, LandTech Consulting, Ridgefield, CT. Bedrock mapping.

1982-84, Research Assistant, Univ. of Kentucky, Natural resource mapping, Jalisco and Colima, Mexico.

1979-1980 Mineralogist, Newmont Exploration, Danbury, CT.

1977-1980 Geologist, Weston Geophysical, Westboro, MA.

1975-1977 Research Assistant, Weston Observatory, Weston, MA.

### Education

1981-1983 University of Kentucky, Lexington, KY., graduate studies in geology, soil science.

1973-1977 Boston College, Chestnut Hill, MA., BS Geology & Geophysics

1969-1973 Ridgefield High School, Ridgefield, CT.

Soil science course work, Univ. of Massachusetts, North Carolina State Univ.

### Professional Organizations

Registered Professional Soil Scientist, Society of Soil Scientists of Southern New England  
Association of Women Geoscientists.

# Short Environmental Assessment Form

## Part 1 - Project Information

### Instructions for Completing

**Part 1 – Project Information.** The applicant or project sponsor is responsible for the completion of Part 1. Responses become part of the application for approval or funding, are subject to public review, and may be subject to further verification. Complete Part 1 based on information currently available. If additional research or investigation would be needed to fully respond to any item, please answer as thoroughly as possible based on current information.

Complete all items in Part 1. You may also provide any additional information which you believe will be needed by or useful to the lead agency; attach additional pages as necessary to supplement any item.

<b>Part 1 – Project and Sponsor Information</b>			
Name of Action or Project: Michael Lehrer & Round Hill Land Corp.			
Project Location (describe, and attach a location map): 92-94 Round Hill Road			
Brief Description of Proposed Action: Wetland mitigation. See plans prepared by Bibbo Associates, LLP, submitted herewith.			
Name of Applicant or Sponsor: Michael Lehrer		Telephone: (914) 421-1800	
		E-Mail:	
Address: 92 Round Hill Road			
City/PO: Armonk		State: NY	Zip Code: 10504
1. Does the proposed action only involve the legislative adoption of a plan, local law, ordinance, administrative rule, or regulation? If Yes, attach a narrative description of the intent of the proposed action and the environmental resources that may be affected in the municipality and proceed to Part 2. If no, continue to question 2.			NO <input type="checkbox"/>
			YES <input type="checkbox"/>
2. Does the proposed action require a permit, approval or funding from any other government Agency? If Yes, list agency(s) name and permit or approval:			NO <input type="checkbox"/>
			YES <input type="checkbox"/>
3. a. Total acreage of the site of the proposed action?		6.50 acres	
b. Total acreage to be physically disturbed?		0.37 acres	
c. Total acreage (project site and any contiguous properties) owned or controlled by the applicant or project sponsor?		6.50 acres	
4. Check all land uses that occur on, are adjoining or near the proposed action:			
5. <input type="checkbox"/> Urban <input type="checkbox"/> Rural (non-agriculture) <input type="checkbox"/> Industrial <input type="checkbox"/> Commercial <input checked="" type="checkbox"/> Residential (suburban)			
<input type="checkbox"/> Forest <input type="checkbox"/> Agriculture <input type="checkbox"/> Aquatic <input type="checkbox"/> Other(Specify):			
<input type="checkbox"/> Parkland			

	NO	YES	N/A
5. Is the proposed action, a. A permitted use under the zoning regulations? b. Consistent with the adopted comprehensive plan?	<input type="checkbox"/>	<input checked="" type="checkbox"/>	<input type="checkbox"/>
	<input type="checkbox"/>	<input checked="" type="checkbox"/>	<input type="checkbox"/>
6. Is the proposed action consistent with the predominant character of the existing built or natural landscape?	NO	YES	
7. Is the site of the proposed action located in, or does it adjoin, a state listed Critical Environmental Area? If Yes, identify: _____	NO	YES	
8. a. Will the proposed action result in a substantial increase in traffic above present levels? b. Are public transportation services available at or near the site of the proposed action? c. Are any pedestrian accommodations or bicycle routes available on or near the site of the proposed action?	NO	YES	
9. Does the proposed action meet or exceed the state energy code requirements? If the proposed action will exceed requirements, describe design features and technologies: _____ _____	NO	YES	
10. Will the proposed action connect to an existing public/private water supply? If No, describe method for providing potable water: _____ _____	NO	YES	
11. Will the proposed action connect to existing wastewater utilities? If No, describe method for providing wastewater treatment: _____ _____	NO	YES	
12. a. Does the project site contain, or is it substantially contiguous to, a building, archaeological site, or district which is listed on the National or State Register of Historic Places, or that has been determined by the Commissioner of the NYS Office of Parks, Recreation and Historic Preservation to be eligible for listing on the State Register of Historic Places?  b. Is the project site, or any portion of it, located in or adjacent to an area designated as sensitive for archaeological sites on the NY State Historic Preservation Office (SHPO) archaeological site inventory?	NO	YES	
13. a. Does any portion of the site of the proposed action, or lands adjoining the proposed action, contain wetlands or other waterbodies regulated by a federal, state or local agency?  b. Would the proposed action physically alter, or encroach into, any existing wetland or waterbody? If Yes, identify the wetland or waterbody and extent of alterations in square feet or acres: _____ _____ _____	NO	YES	

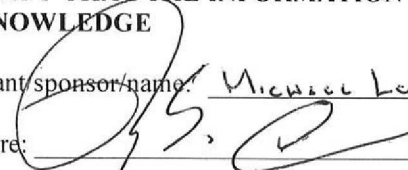
14. Identify the typical habitat types that occur on, or are likely to be found on the project site. Check all that apply: <input type="checkbox"/> Shoreline <input checked="" type="checkbox"/> Forest <input type="checkbox"/> Agricultural/grasslands <input type="checkbox"/> Early mid-successional <input checked="" type="checkbox"/> Wetland <input type="checkbox"/> Urban <input checked="" type="checkbox"/> Suburban		
15. Does the site of the proposed action contain any species of animal, or associated habitats, listed by the State or Federal government as threatened or endangered?	NO	YES
	<input checked="" type="checkbox"/>	<input type="checkbox"/>
16. Is the project site located in the 100-year flood plan?	NO	YES
	<input checked="" type="checkbox"/>	<input type="checkbox"/>
17. Will the proposed action create storm water discharge, either from point or non-point sources? If Yes,	NO	YES
	<input checked="" type="checkbox"/>	<input type="checkbox"/>
a. Will storm water discharges flow to adjacent properties?	<input checked="" type="checkbox"/>	<input type="checkbox"/>
b. Will storm water discharges be directed to established conveyance systems (runoff and storm drains)? If Yes, briefly describe:	<input checked="" type="checkbox"/>	<input type="checkbox"/>
_____		
_____		
18. Does the proposed action include construction or other activities that would result in the impoundment of water or other liquids (e.g., retention pond, waste lagoon, dam)? If Yes, explain the purpose and size of the impoundment:	NO	YES
_____	<input checked="" type="checkbox"/>	<input type="checkbox"/>
_____		
19. Has the site of the proposed action or an adjoining property been the location of an active or closed solid waste management facility? If Yes, describe:	NO	YES
_____	<input checked="" type="checkbox"/>	<input type="checkbox"/>
_____		
20. Has the site of the proposed action or an adjoining property been the subject of remediation (ongoing or completed) for hazardous waste? If Yes, describe:	NO	YES
_____	<input checked="" type="checkbox"/>	<input type="checkbox"/>
_____		
<b>I CERTIFY THAT THE INFORMATION PROVIDED ABOVE IS TRUE AND ACCURATE TO THE BEST OF MY KNOWLEDGE</b>		
Applicant/sponsor name: <u>Michael LeHrer</u> Date: <u>9/11/23</u>		
Signature:  Title: <u>Partner Bibbo Assoc., LLP</u>		